



MES Electrode  
Steam Humidifiers

---

# Installation, Operation, Maintenance, Spare Parts, and Exploded Views Guide

**IMPORTANT:** Read and save this guide for future reference.  
This guide to be left with equipment owner.



# Table of Contents

---

<b>INSTALLATION</b>	<b>1</b>
RECEIVING EQUIPMENT . . . . .	1
PRINCIPAL OF OPERATION . . . . .	1
WATER SUPPLY AND PLUMBING . . . . .	2
WATER CONNECTION . . . . .	2
START-UP AND OPERATION . . . . .	2
CAPACITY ADJUSTMENT. . . . .	3
CYLINDER REPLACEMENT. . . . .	3
WHEN TO REPLACE THE STEAM CYLINDER . . . . .	3
REMOVING THE OLD CYLINDER . . . . .	4
INSTALLING THE NEW CYLINDER. . . . .	4
<b>MAINTENANCE</b>	<b>4</b>
EXTENDED SHUTDOWN . . . . .	4
<b>TROUBLESHOOTING</b>	<b>4</b>
TERMS USED . . . . .	4
STARTING POINT . . . . .	5
DIAGNOSTIC PROCEDURES TROUBLESHOOTING GUIDE. . . . .	7
SOFTWARE REQUIREMENT FOR MODBUS RTU . . . . .	8
PHYSICAL DIMENSIONS DIAGRAM . . . . .	11
WIRING DIAGRAMS . . . . .	12
SPARE PARTS LIST . . . . .	14
EXPLODED VIEWS DIAGRAM . . . . .	15

# INSTALLATION

## RECEIVING EQUIPMENT

1. Check packing slip to ensure ALL material has been received.
2. Inspect box for damage and note on shipping waybill accordingly.
3. After unpacking, inspect unit for damage and if damage is found, advise shipper as soon as possible.
4. Inspect unit (humidifier) to ensure it is the correct model, phase, and voltage. If any are incorrect, advise the factory or your local representative immediately.

**NOTE:** All products are shipped on an F.O.B. factory basis. Any and all damage, loss, or breakage claims are to be made directly to the shipping company.

The NORTEC MES Series electrode humidifier is the culmination of many years of research and development in the electrode humidifier industry. This unit has been built by skilled craftspeople and thoroughly tested before shipment and should, if the following instructions are observed, provide many years of trouble-free operation.

**FOR HUMIDIFIERS INSTALLED IN THE CITY OF LOS ANGELES:** A city of Los Angeles approved spring-loaded double ball CHECK VALVE should be supplied and installed by the contractor on each of the potable water inlets to each humidifier.

Recommended valve manufacturer: Watts Regulator (phone 508-688-1811), model #7, size 3/8" NPT inlet and outlet.

Each drain line from these humidifiers shall be routed, without dips or sags, to terminate above the flood level rim of a City of Los Angeles approved indirect waste receptor.

No combustible materials shall be placed in the duct and/or the air plenum.

## PRINCIPAL OF OPERATION

When the humidistat calls, the cylinder fills to 100% of the Full Load Amperage (F.L.A.) or to the top of the cylinder, whichever comes first. See Figure #1.

If it reaches 100% F.L.A. the water heats and boils away to a level giving 80% F.L.A.

**Figure #1**  
**Operation Schematic**

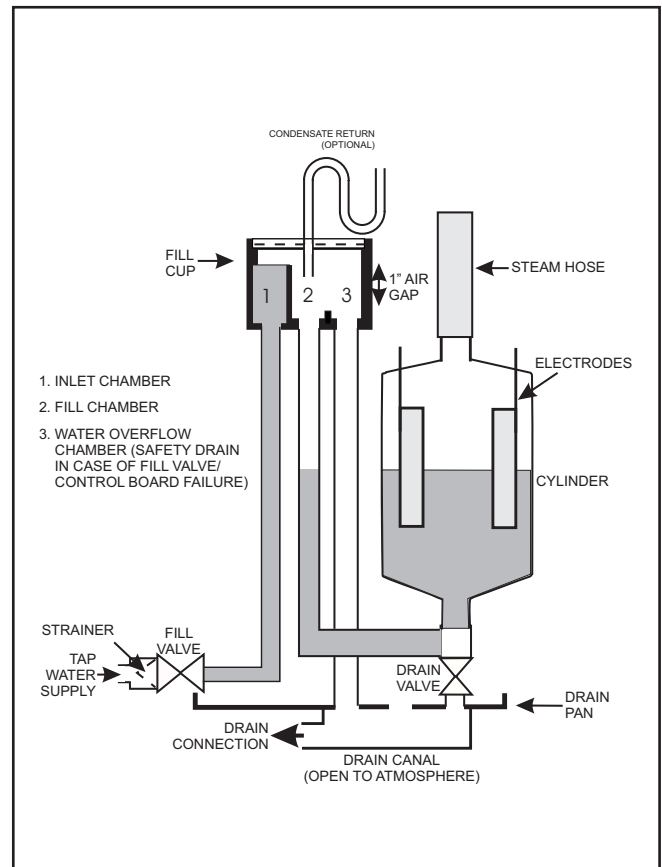

An electronic timer uses the rate of amp fall to determine the water level. The objective is to concentrate current-carrying minerals in the cylinder so that a smaller volume of water is required to produce the rated steam output.

This achieves the longest life for the disposable cylinder because of minimal electrode coverage and use of less energy because the high concentration allows a minimal drain rate.

When 80% F.L.A. is reached, the fill valve will open refilling cylinder to 100% F.L.A. On occasion, the drain valve will also come on if water level is too low, indicating too high a concentration and the requirement for a dilution of the water in the cylinder.

If the water reaches top of cylinder before 100% F.L.A., the fill valve shuts off via the sensor and fill-boil-fill-boil cycle continues, cycling off the red high water sensor light until the concentration becomes high enough to reach 100% F.L.A. The above described control process will then take over.

## WATER SUPPLY AND PLUMBING

1. The fill valve is sized for an extended water pressure range of 30 to 80 psi.
2. For cases below 30 psi add a pressure boost pump, notify the factory and a fill valve with an oversized orifice will be supplied.
3. For cases above 80 psi, install a pressure reducing valve in the water feed line to the unit.
4. With extremely dirty or muddy water sources, e.g., some well sources, ensure proper filtration by adding an external filter to the water line entering the unit. (Consult factory for accessories such as filters.)
5. DO NOT use completely demineralized water with this unit as it is the minerals that allow the electrode principle to work.
6. DO NOT use a hot water source as it will cause deposits that will eventually block the fill valve orifice.

**Figure #2**  
**Bottom View of MES Series Unit**

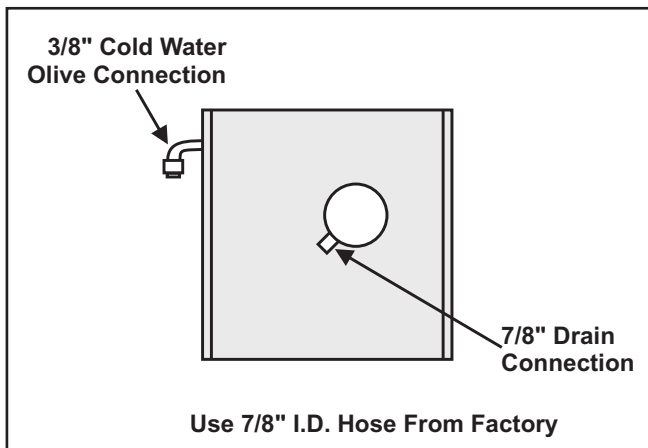

## WATER CONNECTION

1. A copper compression olive type coupling for 1/4" O.D. soft copper tubing is provided with unit and requires no soldering for the water connection to the unit. See Figure #2.
2. An isolating valve should ALWAYS be placed in the feed water line allowing service of the fill valve.
3. Each unit is fitted with a fill solenoid valve located on the base drain pan. Flow orifices

are designed for water pressure from 30 to 80 psi and are protected by the built-in strainer.

4. For inlet water pressure outside this range, the factory should be contacted. (See Water Supply and Plumbing section of this manual.)

## START-UP AND OPERATION

- Ambient temperature location for humidifier: 41°F - 104°F (5°C - 40°C).
- Relative humidity location for humidifiers: 5% rh - 80% rh.

Check to see that the unit is securely mounted on a level surface with the proper drain and water supply. Check for correct voltage with appropriately sized service. Check that the steam distributor, steam supply hose, and condensate line are correctly installed and routed back to the unit. Ensure that the external control humidistat is located in an area to properly sense the relative humidity to be maintained by the humidifier, and that the interconnecting low voltage wires between the humidistat and the unit's control terminal strip are in accordance with the wiring diagram.

Check **all electrical connections** for wires which may have become **loose in shipping**. Components damaged due to loose connections are **NOT** under warranty.

Check electrode plugs to ensure they are pressed firmly onto the electrode pins. **Important:** Loose connections will cause overheating of the cylinder plugs, possibly melting the plugs and/or cylinder.

Open the isolating valve in the feed water line to the unit.

Make sure the humidistat is set high enough to call for humidification.

Turn on the main disconnect in the primary service feeding the unit and check that unit has power at the primary terminal block.

PUSH THE AUTO ON/OFF/DRAIN SWITCH TO "ON".

Water will start to enter the cylinder through its bottom port and rise in the cylinder to a point determined by the solid-state control circuitry.

**It is not unusual upon initial start-up for the water to fill the cylinder and cycle on the red high water sensor light.**

The red light simply acts as a safety to shut off the fill valve and prevent over-filling. With the red light on, the water in the cylinder will continue to heat and, after a few minutes, start to boil. After the boiling action of the water has lowered the water level below the sensor at the top of the cylinder, the red light will go out and the fill solenoid will again open until the cylinder is again full.

This cycling of the red light and fill valve will continue until the unit's full output capacity is reached after which the water level will automatically lower itself in the cylinder. (The increased concentration allows for lower electrode coverage while maintaining the same output.) When a stabilized condition is reached the water will be boiling close to the cylinder seam level. The solid state circuitry will maintain the proper concentration in the cylinder by introducing short drains only when necessary.

If the cylinder is manually drained the above process will repeat itself.

**Low Water Conductivity**

Should normalization of the unit be required immediately after start-up, the installer may speed up the process by artificially increasing water conductivity. During a fillcycle, the installer should dissolve half a teaspoon of table salt (no more) in a cup of water and add it to the cylinder by means of the fill cup attached to the plumbing section.

Open the plumbing compartment and add salt solution through cylinder outlet. Excessive amounts of salt will result in erratic operation of the unit; however, normalization of the unit will occur automatically through the solid-state control sequence.

**CAPACITY ADJUSTMENT**

The MES Series of humidifiers come with adjustable capacity (AC) PC boards. These boards have a pot to adjust the output from 20 to 100%. See Figures # 3 and 4.

**Figure #3  
MES Adjustable Pot**

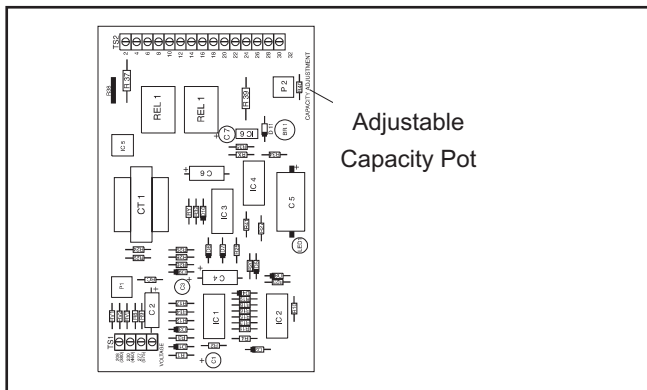

**Figure #4  
MES Adjustable Pot**

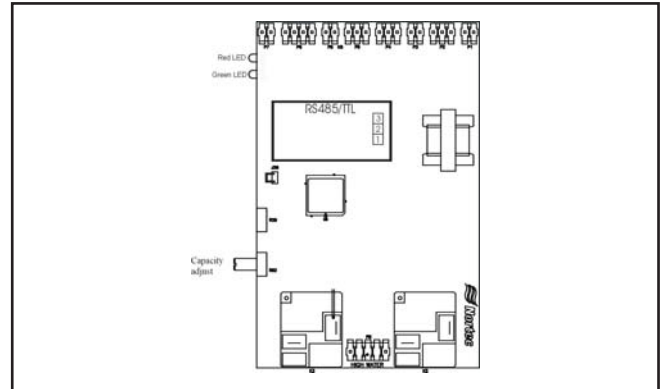

**CYLINDER REPLACEMENT**

After an extended period of operation, in accordance with life expectancy information, the cylinder is completely used as indicated by the red high water sensor light illuminated on the cabinet. When this condition is reached, a new replacement cylinder is to be installed.

**NOTE:** Red light may come on during initial start-up but does not mean cylinder replacement. See Start Up and Operation section of this manual.

**Figure #5  
Cylinder Removal**

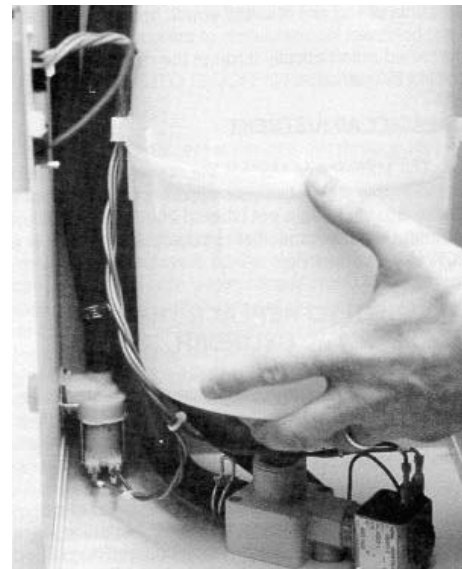

Consult factory or agent for replacement. Quote the cylinder model from the white 3-digit label on the cylinder or quote model, voltage, and serial number from unit specification label.

**WHEN TO REPLACE THE STEAM CYLINDER**

The steam cylinder is disposable and must be replaced at the end of cylinder life. Cylinder life is

dependent on water supply conditions and humidifier usage. Failure to replace the cylinder at the end of cylinder life may result in unit damage. Walter Meier (NORTEC) is not responsible for any damages resulting from, or attributable to, the failure to replace a used cylinder (see Manufacturer's Warranty).

### REMOVING THE OLD CYLINDER

- See Figure # 5.
1. Turn off the water supply to unit.
  2. The old cylinder must be drained completely before removing. This is done by pushing the auto on/off/drain switch to the "drain" position.
  3. When completely drained, push the auto on/off/drain switch to the "off" position.
  4. Open the main disconnect during the entire cylinder change operation.
  5. The power wires to the cylinder are attached by cylinder plugs to the electrode pins on top of the cylinder. Pull these plugs vertically off the pins. See Figure # 5.
  6. Using slot screwdriver, loosen the steam hose clamp(s) and pull steam hose off vertically.

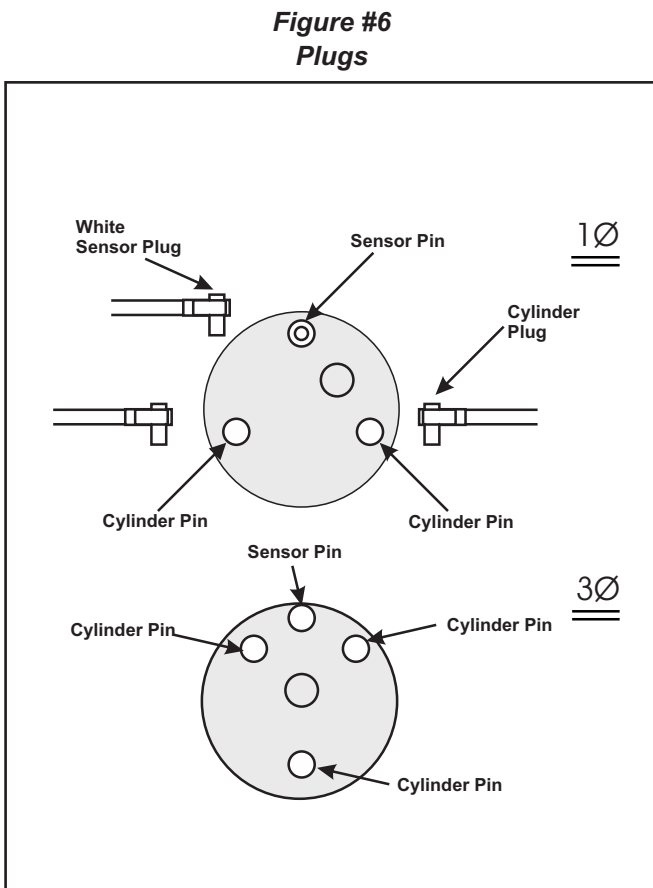

7. The cylinder is now ready to be lifted out of the unit.

### INSTALLING THE NEW CYLINDER

1. The reverse procedure should be followed to install a new cylinder. The main disconnect is to be left open until the cylinder is completely installed and reconnected.
2. Ensure that the cylinder mounting stubs are seated properly in the allotted side mounting slots within the unit.
3. The white sensor plug on all units is for the sensor pin, which always goes on the single pin offset from the others. See Figure # 6.
4. Ensure that cylinder plugs are very snug on the pins. Replace any loose fitting plugs as these may result in hazardous operation.

## MAINTENANCE

**WARNING!** The plumbing and electrical compartments contain high voltage components and wiring. The access cover is attached with screws. Access should be limited to authorized personnel only.

### EXTENDED SHUTDOWN

Before disconnecting power to the humidifier for a period of extended shutdown, ALWAYS DRAIN the cylinder first. Otherwise, the electrodes are subject to harmful corrosion which drastically shortens the cylinder life. Do NOT leave the switch in the DRAIN position indefinitely as the drain coil could burn out. Leave the switch in the OFF position and "open" the main external fused disconnect to stop power to the humidifier. Close the shut off valve in the water supply line feeding the humidifier.

## TROUBLESHOOTING

### TERMS USED

**F.L.A. (Full Load Amps):** Refers to amps listed on the humidifier specification label.

**SHORT CYCLING:** When the 'on time' of the humidifier is less than ten minutes upon a call for humidity. To correct short cycling, all humidifiers have a capacity adjustment which allows the output of the humidifier to be reduced to as low as 20% of rated output, thus extending the 'on time' required to maintain output.

**FOAMING:** The phenomenon which can occur in water when impurities, already in the water reach an excess concentration as a result of boiling away pure water and the continued boiling action agitating the contained water. The humidifier electronics are designed to prevent this occurrence although in extreme cases, water will foam with little concentration making it necessary to have the drain time of the water, contained in the cylinder, increased. Foaming is normally caused by short cycling, a restricted drain, or back pressure. The foam, generated in these instances, is conductive and may lead to false full cylinder indication if the level of the foam approaches the top of the cylinder.

**BACK PRESSURE:** The restriction of steam flow caused by long steam runs, improperly sloped steam lines, elbows changing the direction of steam flow from horizontal to vertical without a drain leg, any plumbing detail allowing the accumulation of condensate, undersized steam line, improper steam distributor, downward air flow onto the distributor causing excess static pressure at the steam outlets, or high static pressure ducts (not probable). To overcome excess static pressure in the duct, a fill cup extension kit should be used. In down flow applications, a down flow distributor should be used, but in some cases the fill cup extension will also be required.

**RESET UNIT (HUMIDIFIER):** To reset the humidifier, the auto on/off/drain switch at the front of the humidifier should be switch to the "Off" position for a minimum of five seconds and then switched back to the "On" position.

**MONITORED LEG:** Refers to the primary wire to the cylinder which loops through the current sensing devise of the main PCB. This wire is terminated at the red cylinder plug at the cylinder.

## STARTING POINT

### Auto On/Off/Drain switch in "On" position - unit will not fill:

When the on/off control circuit is made and the "auto on/off/drain" switch is pushed to "on", the 24 volt holding coil of the primary contactor should energize. The resulting magnetic pull closes the high voltage contacts with a distinct and audible "clunk". If the contactor will not make, then inspect the following while referring to the wiring diagram:

1. Check for 24 Vac across terminals 18 and 26 on PC board.
2. Jumper the humidistat on external control terminal strip. If contactor operates, then control system is at fault.

3. The low voltage 3 amp fuse located in the control box could be blown.
4. The contactor holding coil could be open or shorted.
5. The switch could be defective.

Recheck that the "auto on/off/drain" switch is still at "on". If it is, then shut off the main disconnect and check fuses or breaker of the main disconnect. If they are serviceable, turn power back on.

To test for a defective "auto on/off/drain" switch, connect a wire from the fuse directly to terminal 6 on the external controls strip. If the contactor activates, the "on" side of the switch is defective. If the contactor does not activate, the PC board could be defective.

If the 3 amp control fuse blows when the wire from the fuse touches terminal 6 on the external controls strip, contactor holding coil could be shorted. Replace contactor if necessary.

After the necessary components have been replaced and the contactor pulls in, there is line voltage to the cylinder and the control sequence can begin.

Approximately 30 seconds after the contactor pulls in, the fill valve coil should energize. There is also a visible fill relay on the printed circuit board. It is the one located farthest from the C.T. core. The points on this relay must be touching in order for the fill valve coil to be energized.

If the points will not touch after the built-in time delay, then the sensor input may be interfering. To confirm, remove the black and red sensor wires from the terminals 6 and 10 on the PC board. Wait 30 seconds and if the fill relay points not touch, then sensor should be replaced. If they do not touch, then the basic PC board could be faulty. To confirm, disconnect the red wire from terminal 18 and touch it to terminal 14. If the fill valve coil activates then the basic PC board should be replaced. If it still does not activate then the fill valve coil should be replaced.

Having changed the necessary components, water starts filling the cylinder and begins to submerge the electrodes. Because of the high voltage across the electrodes, the water can now conduct electricity.

### Red "Change Cylinder" light on - Water at top of cylinder:

This is a common occurrence on start-up. See Start-Up and Operation section of this manual.

If the cylinder is old, it indicates end of cylinder life. Time to replace the cylinder. See “When To Replace The Steam Cylinder” section of this manual.

**Red “Change Cylinder” light on - Water NOT at top of cylinder:**

Water foaming to top of cylinder causing false full cylinder indication. This also may be accompanied by arcing (flashing) inside cylinder. Refer to “Terms Used” regarding foaming.

**Water remains at high level and won’t concentrate:**

This is normal on cold start-up and can be accelerated by adding maximum 1/2 tsp. of dissolved salt to the cylinder (through the plastic fill cup) on fill cycle. See “Low Water Conductivity” section of this manual.

If unit has been operating extensively, observe for normal fill-boil-fill-boil cycle; no drain should be occurring. If drain occurring, check for leaking drain valve or back pressure.

**Water beyond top of cylinder up into spout:**

If the red light is not on and fill is still activated, jumper across the connection of sensor on basic PC board. If fill remains on when connection is jumped, then basic PC board is faulty. If fill shuts off, then verify primary voltage to cylinder (contactor energized). If primary voltage is present, the high water sensor PCB is defective.

**Unit drains continually:**

May be caused by foaming and/or back pressure, or leaking drain valve.

Cylinder is almost empty, check for magnetic pull on drain solenoid indicating miswiring. If no pull, drain actuator is blocked open; remove, disassemble and clean.

If drain is occurring through activated drain valve, valve is miswired or electronics are faulty - consult factory.

If drain is occurring through the overflow on the fill cup, this is due to abnormal restriction on the steam line and back pressure forces water out of the cylinder; therefore, water cannot concentrate and level must stay high; review installation of steam line to ensure no blockages or excessive static pressure in air system.

## DIAGNOSTIC PROCEDURES - TROUBLESHOOTING GUIDE

Unit Status Lamp		Symptom	Corrective actions
Yellow	Green		
On	On	Maximum water level inside cylinder.	<p>This usually happens on initial start-up after replacing the cylinder (normal).</p> <p>Water is concentrated with minerals inside the cylinder.</p> <p>Let unit run, yellow light will disappear when the unit is at full output. This may take a day or two.</p>
Off	Off	No power to the board.	<p>Check for main power supply fault.</p> <p>Turn power switch to 'Drain' position. If drain valve is activated (sound of solenoid), check connection to the board or board itself.</p> <p>When no sound present, check fuse (replace with 3.0 A if needed), transformer (voltage should be present between fuse holder and ground screw).</p>
1 flash sequence	Off	Excess current. Operating amperage exceeded 130% of rated amps. Water is drained from the cylinder (drain valve on for 10 min.).	<p>Check drain valve operation, drain time, possible drain restrictions.</p> <p>Check if fill valve leaks (not holding supply water).</p> <p>Back pressure may also cause very conductive water conditions.</p> <p>Was the humidifier short cycling?</p> <p>Check for short cycling.</p> <p>Water conductivity too high.</p>
2 flashes in sequence	Off	No current detection for 30 minutes with continuous call for humidity.	<p>Check water level in the cylinder - should be more than ¼ full. If not check fill rate, 24 VAC voltage on fill valve terminals (unit must be on with call for humidity - green light steady on). Verify fresh water supply to the humidifier. Leaking drain valve can be at fault (minerals blocking the plunger).</p> <p>If cylinder is more than ¼ full, check primary power, connections to the cylinder, continuity of wires to cylinder.</p> <p>Are power wires connected to proper terminals on the cylinder? (Color coding)</p> <p>Possibly wrong cylinder type.</p> <p>Low water conductivity.</p>
4 flashes in sequence	Off	End of cylinder life - change cylinder.	<p>Check water level in the cylinder, should be about ¾ full.</p> <p>Check for foaming if water level lower or cylinder life shorter than expected.</p> <p>Change cylinder, clean drain valve.</p>

## SOFTWARE REQUIRMENTS FOR MODBUS RTU

**Modbus addresses:**

**4XXXX - R/W**

**3XXXX - R**

Command	Description	MODBUS address	Details
Output Control	<p>OFF                      ON</p> <p>Disables the humidifier and places the humidifier in standby mode</p> <p>Enables the humidifier (humidifier will operate based on the SET OUTPUT command input)</p> <p>After a microprocessor reset, the default setting for Output Control shall be OFF.</p>	40262	<p>255: inhibit actions of humidifier</p> <p>0: allow normal operation</p>
Set Output	<p>Sets the desired steam output from 0-100%</p> <p>This value shall be zero after a microprocessor reset</p>	40264	<p>Remotely set humidity reading over network. Value of 0 to 100 (per cent). If no network signal for N minutes, reverts to 0.</p>
Force Drain	<p>When written to (FF), will interrupt the humidification process and activate the humidifier drain valve. After 20 minutes the controller will reset this value (00).</p> <p>After a microprocessor reset, the default setting shall be (00)</p>	40276	<p>255 will start the process, 0 will be accepted, to clear if the request has not been cleared itself</p>
Set MODBUS address*	<p>Change the humidifier controller's MODBUS address.</p> <p>Range is 1-247.</p> <p>This setting shall be non-volatile with a default setting of 1.</p>	40550	<p>The value changes will only take effect following a hardware reset of the control board.</p>
Set MODBUS Baud rate*	<p>Changes the humidifier's baud rate.</p> <p>Range is 4800, 9600, and 19200 B/sec.</p> <p>This setting shall be non-volatile with a default value of 9600 B/sec.</p>	40552	<p>The value changes will only take effect following a hardware reset of the control board</p>
Set MODBUS parity*	<p>Change the humidifier controller's MODBUS parity.</p> <p>Range is None, Even, Odd</p> <p>This setting shall be non-volatile with a default setting of Even.</p>	40554	<p>The value changes will only take effect following a hardware reset of the control board</p>

Reset Run Hour Counter	Resets the humidifier controller's run hour counter to zero hours	40560	255 will start the run hours counter process. 0 will be accepted to clear the run hours counter.
Current damping	Buffers the measured current	40510	From 0 to maximum (depending on software ability)
Electrode current	The value of the electrode current in Amps	30850	Hex value representing the humidifies current in amps Resolution: 0.10 amps Example: 015F (hex) = 35.1 Amps
Steam output	The current steam output in Kg/Hr. or LBS/hr  See UNITS (Modbus 40031)	30860	Hex value representing the humidifies steam output in kg/hr Resolution: 0.10 kg or LBS Example: 013B (hex) = 31.5 kg/hr or LBS/hr
Run hour counter	The number of hours the humidifier has been in operation since the last time the run hour counter was reset	30414	Hex value representing the number of humidifier oper additional hours since the last reset. Resolution: 5 minutes Maximum count: 5460 Hours. Example: 07D0 = 2000 hours
Firmware version	The firmware version of the humidifier controller	30361	Packed BCD version 3.52 would be 0x0352
Humidifier state	Describes the current state of the humidifier and it's I/O's Contactor ON/OFF Fill Valve ON/OFF Drain Valve ON/OFF	30800	Bit Allocation Note More than one bit can be active at any time. Contactor on = 1 Fill valve on = 2 Drain valve on = 4
Maximum production	The rated maximum steam production for the humidifier	30802	Value written into Unit type (40600) is also stored here
Alarms	The humidifier shall describe any faults Too long to fill Excess Current End of cylinder life No current	30364	Bit Allocation Note More than one bit can be active at any time. Too long to fill = 1 Excess current = 2 End of cylinder life = 4 No Current = 8

Units	Required by the control board for capacity calculations	40031	0: 0-1. 0=LBS, 1=KG																								
Unit type	Required by the control board for current and capacity calculations	406000	Depending on the setting in UNITS (Modbus: 40031) Hex value representing maximum unit capacity (100% fill off amps)																								
Unit voltage	Required by the control board for current and capacity calculations	40610	Format is Hexadecimal numeration table (see below) <table border="1" data-bbox="1149 514 1421 1276"> <thead> <tr> <th>Hex Value</th> <th>Unit Type</th> </tr> </thead> <tbody> <tr> <td>0</td> <td>110-120</td> </tr> <tr> <td>1</td> <td>208</td> </tr> <tr> <td>2</td> <td>220-240</td> </tr> <tr> <td>3</td> <td>230</td> </tr> <tr> <td>4</td> <td>277</td> </tr> <tr> <td>5</td> <td>347</td> </tr> <tr> <td>6</td> <td>380</td> </tr> <tr> <td>7</td> <td>400</td> </tr> <tr> <td>8</td> <td>415</td> </tr> <tr> <td>9</td> <td>440-480</td> </tr> <tr> <td>A</td> <td>550-600</td> </tr> </tbody> </table>	Hex Value	Unit Type	0	110-120	1	208	2	220-240	3	230	4	277	5	347	6	380	7	400	8	415	9	440-480	A	550-600
Hex Value	Unit Type																										
0	110-120																										
1	208																										
2	220-240																										
3	230																										
4	277																										
5	347																										
6	380																										
7	400																										
8	415																										
9	440-480																										
A	550-600																										
Unit phase	Required by the control board for current and capacity calculations.	40620	Bit Allocation Single phase = 1 Three phase = 2 Three phase (6 electrode) = 4																								

## DIMENSIONS

MES-U / MES	DEPTH	WIDTH in.(cm)		HEIGHT
	in.(cm)	(REMOTE ELECTRICAL)	(ATTACHED ELECTRICAL)	in.(cm)
5 *	6.6 (16.7 cm)	8.6 (21.9 cm)	10.7 (27.1 cm)	13.5 (34.4 cm)
10	6.6 (16.7 cm)	8.6 (21.9 cm)	10.7 (27.1 cm)	17.3 (43.9 cm)
15	8.4 (21.3 cm)	10.5 (26.7 cm)	12.6 (32.2 cm)	19.4 (49.3 cm)
20	8.4 (21.3 cm)	10.5 (26.7 cm)	12.6 (32.2 cm)	19.4 (49.3 cm)
25	10.5 (26.7 cm)	10.5 (26.7 cm)	12.6 (32.2 cm)	21.3 (54.0 cm)
30	10.5 (26.7 cm)	10.5 (26.7 cm)	12.6 (32.2 cm)	21.3 (54.0 cm)

## WEIGHTS (DRY)

CONFIGURATION	1	2	3	4	5	6	7	8	9
MES-U / MES	lbs(kg)	lbs(kg)	lbs(kg)	lbs(kg)	lbs(kg)	lbs(kg)	lbs(kg)	lbs(kg)	lbs(kg)
5*	8.2 (3.7)	9.6 (4.3)	9.0 (4.1)	10.4 (4.7)	13.7 (6.2)	13.1 (6.0)	14.5 (6.6)	8.8 (4.0)	13.0 (5.9)
10	8.7 (4.0)	10.1 (4.6)	9.5 (4.3)	10.9 (4.9)	14.2 (6.4)	13.7 (6.2)	15.0 (6.8)	9.4 (4.2)	13.5 (6.1)
15/20	12.6 (5.7)	13.9 (6.3)	13.4 (6.1)	14.8 (6.7)	22.0 (10.0)	21.5 (9.7)	22.9 (10.4)	13.2 (6.0)	21.3 (9.7)
25/30	14.1 (6.4)	15.4 (7.0)	14.9 (6.7)	16.2 (7.4)	23.5 (10.7)	23.0 (10.4)	24.3 (11.0)	14.7 (6.7)	22.8 (10.3)

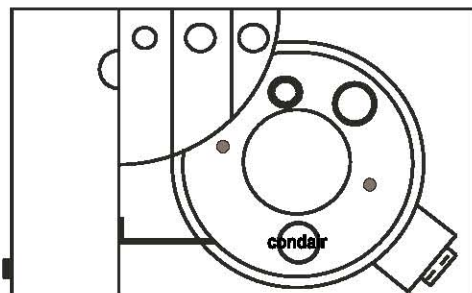

TOP VIEW

### NOTES:

1. FOR HEIGHT OF 5 LB PVC USE HEIGHT OF 10 LB MODEL.
2. PVC = PRIMARY VOLTAGE CONNECTION.
3. MODEL SHOWN: 163-91X5 (CONFIGURATION #5) WITH CP (CLOSED PLUMBING) COVER REMOVED.

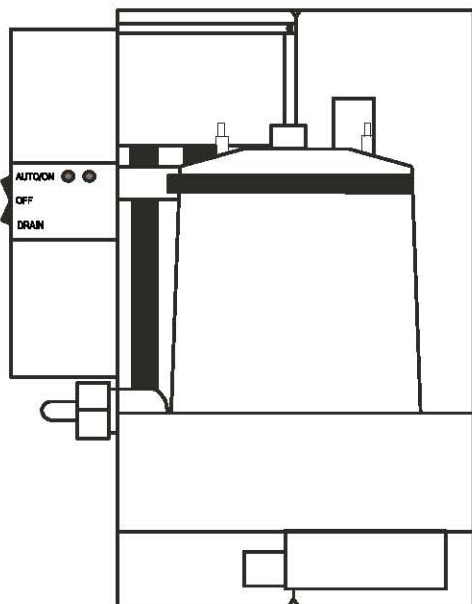

FRONT VIEW

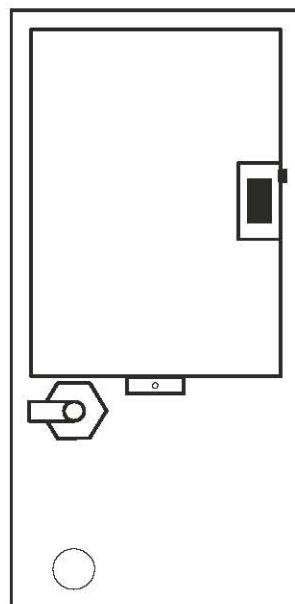

LEFT VIEW



**MES-U/MES HUMIDIFIER**  
MESU DIM 10/19/98  
PHYSICAL DATA

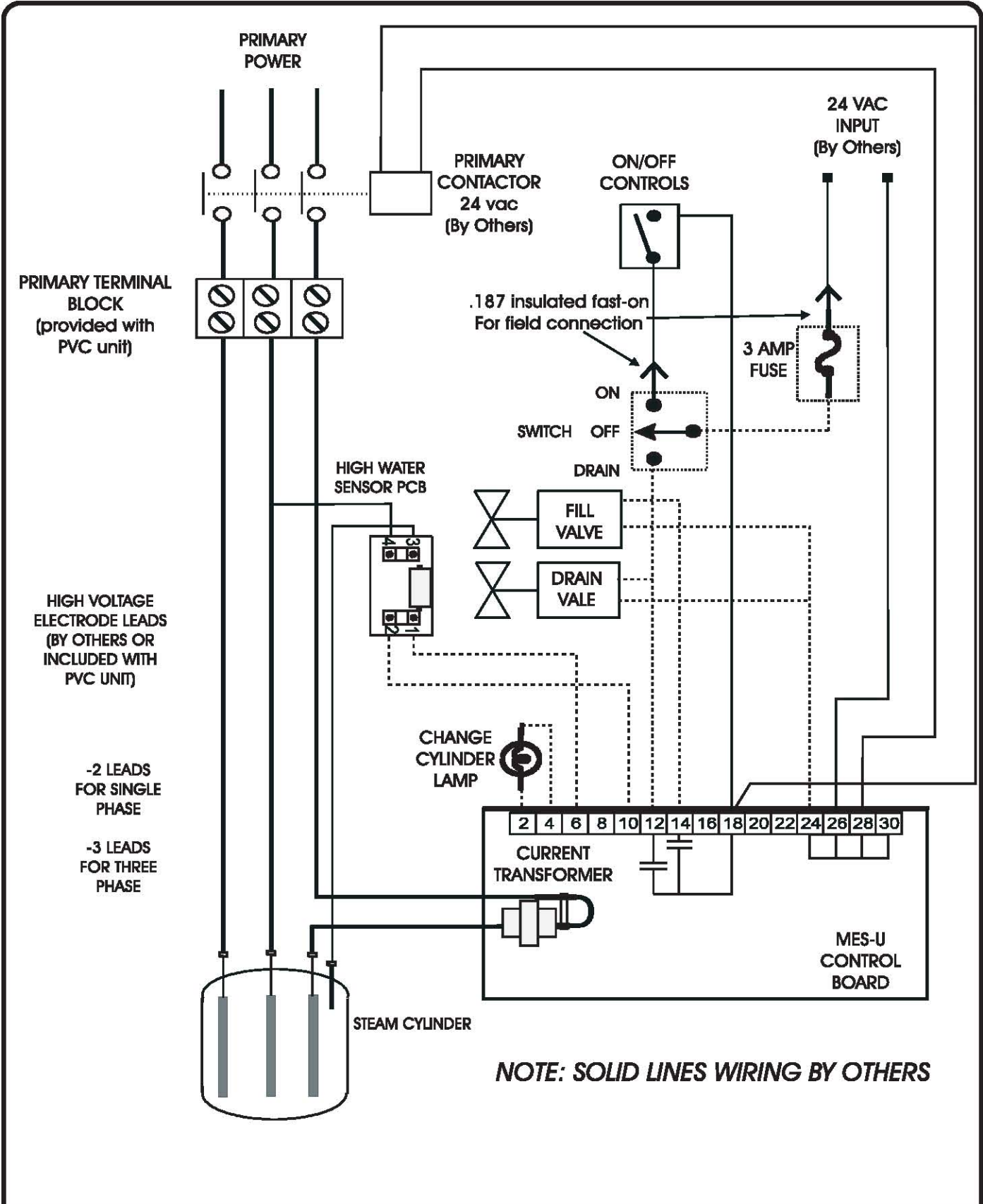

MES-U INTERNAL AND FIELD WIRING  
(For PVC or LVC unit with remote or attached electrical)

WIRING DIAGRAM number 150-6240 REV. B

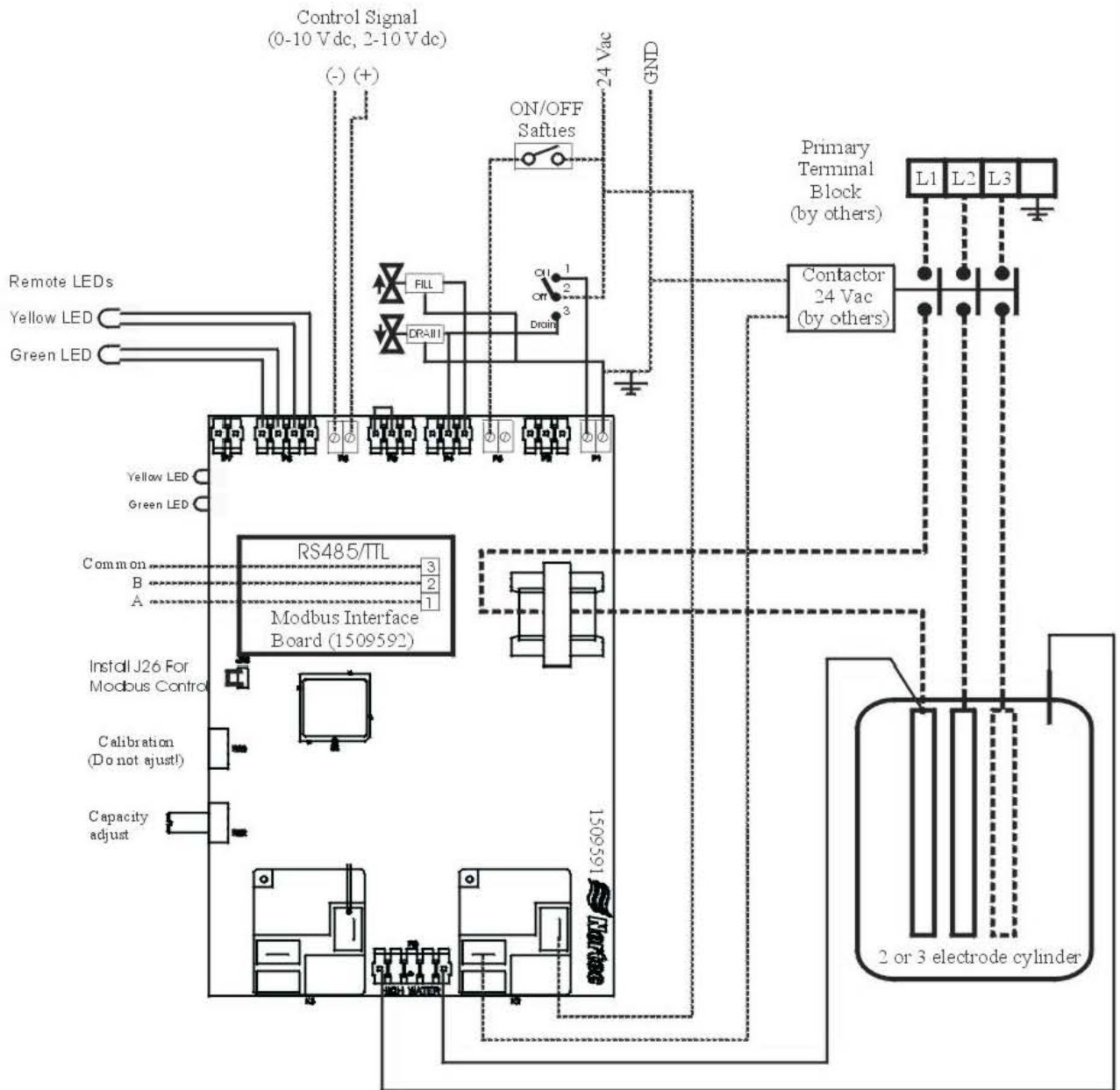

NOTE: Dotted lines denote wiring by others

MES SERIES SPARE PARTS LIST - ELECTRICAL AND PLUMBING

POS. NO	DESCRIPTION	Comments	NORTEC PART NUMBER	MES-U 5 - 10 / 1Ph		MES-U 15 - 20 / 1Ph		MES-U 15 - 20 / 3Ph		MES-U 25 - 30 / 3Ph	
				208/ 230/ 277V	380/ 460/ 575V	208/ 230V 460/ 575V	380/ 460/ 575V	208/ 230V 460/ 575V	380/ 460/ 575V	208/ 230V 460/ 575V	380/ 460/ 575V
				1	Cylinder - To order replacement cylinder, quote the 3-digit number on the cyl. Being replaced or quote the unit serial number, model and voltage from the spec label.	Consult Factory	1	1	1	1	1
2	Cylinder Plug - Sensor H.W.S		150 4150	1	1	1	1	1	1	1	1
3	Cylinder Plug 10AWG Spring Loaded - Black		135 4012B	1	1	1	1	1	1	1	1
4	Cylinder Plug 10AWG Spring Loaded - Red		135 4012R	1	1	1	1	1	1	1	1
5	Cylinder Plug 10AWG Spring Loaded - Yellow		135 4012Y	n/a	n/a	n/a	n/a	1	1	1	1
6	Drain Canal		132 1216	1	1	1	1	1	1	1	1
7	Drain Canal Gasket		163 1026	1	1	1	1	1	1	1	1
8	Drain Canal Screw		132 5064	1	1	1	1	1	1	1	1
9	Drain Canal Washer		132 5046	1	1	1	1	1	1	1	1
10	Drain Hose Nominal 3/4" - 1 ft. length		132 8810	1	1	1	1	1	1	1	1
11	Drain Valve Body - Assembly	w/o coil	132 6003	1	1	1	1	1	1	1	1
12	Drain Valve Body and Coil Assembly		145 6000	1	1	1	1	1	1	1	1
13	Drain Valve Coil Assembly - 24V ASCO2	w/o body	132 6002	1	1	1	1	1	1	1	1
14	Drain Valve Hose and Overflow Hose	Specify Length	132 8860	1	1	1	1	1	1	1	1
15	Drain Valve Hose and Overflow Hose Spring Clamp		132 5035	3	3	3	3	3	3	3	3
16	Drain Valve O-Ring		132 6004	1	1	1	1	1	1	1	1
17	Drain Valve Plastic Stuffing Block		132 1042BR	1	1	1	1	1	1	1	1
18	Drain Valve Screws		145 5002	2	2	2	2	2	2	2	2
19	Drain Valve Spring & Core		132 6002K1	1	1	1	1	1	1	1	1
20	Fill Cup		142 1050	1	1	1	1	1	1	1	1
21	Fill Valve Assembly #1	132 1061	1	1	1	1	1	1	1	n/a	n/a
22	Fill Valve Assembly #2	132 1062	n/a	n/a	n/a	n/a	n/a	n/a	n/a	1	1
23	Fill Valve Hose	Specify Length	132 8850	1	1	1	1	1	1	1	1
24	Fill Valve Spring Clamp		132 5023	2	2	2	2	2	2	2	2
25	Fill Valve Screw		145 5004	2	2	2	2	2	2	2	2
26	Fitting - 1" to 3/8"		149 5072	1	1	1	1	1	1	1	1
27	Fitting - 3/8" to 1/4" compression 90 degree		132 6129	1	1	1	1	1	1	1	1
28	Fuse 3A In-Line		145 1003	1	1	1	1	1	1	1	1
29	Grommet - Closed 7/8"	Closed Plumbing	145 3079	2	2	2	2	2	2	2	2
30	Grommet - Closed 1-1/16"	Closed Plumbing	163 1014	1	1	1	1	1	1	1	1
31	Grommet - Open 7/8"		132 3079	2	2	2	2	2	2	2	2
32	Ground Clamp	PVC * Electrical	132 3020	1	1	1	1	1	1	1	1
33	High Water Sensor Board Standoff		132 5253	1	1	1	1	1	1	1	1
34	High Water Sensor Ligh and Lense		132 3099	1	1	1	1	1	1	1	1
35	High Water Sensor PC Board Assembly		147 4994	1	1	1	1	1	1	1	1
36	Steam Hose Nominal 3/4" - Specify Length		132 8810	1	1	1	1	1	1	1	1
37	Steam hose Clamp		132 5007	4	4	4	4	4	4	4	4
38	Switch -On/Off		132 3097	1	1	1	1	1	1	1	1
39	Terminal Block 65A 1PH	PVC * Electrical	147 3002	1	1	1	1				
	Terminal Block 65A 3PH	PVC * Electrical	163 1050					1	1	1	1
40	Tie Wrap - Reusable		151 3003	1	1	1	1	1	1	1	1
	PCB - To order replacement PC Board, quote the 7-digit number on the board label, or, quote the unit serial number model and voltage from the spec label	Consult Factory		1	1	1	1	1	1	1	1
41				1	1	1	1	1	1	1	1
42	MES-P Replacement PCB Board		1509591	1	1	1	1	1	1	1	1
43	MES-P Replacement Modbus driver board		1509529	1	1	1	1	1	1	1	1

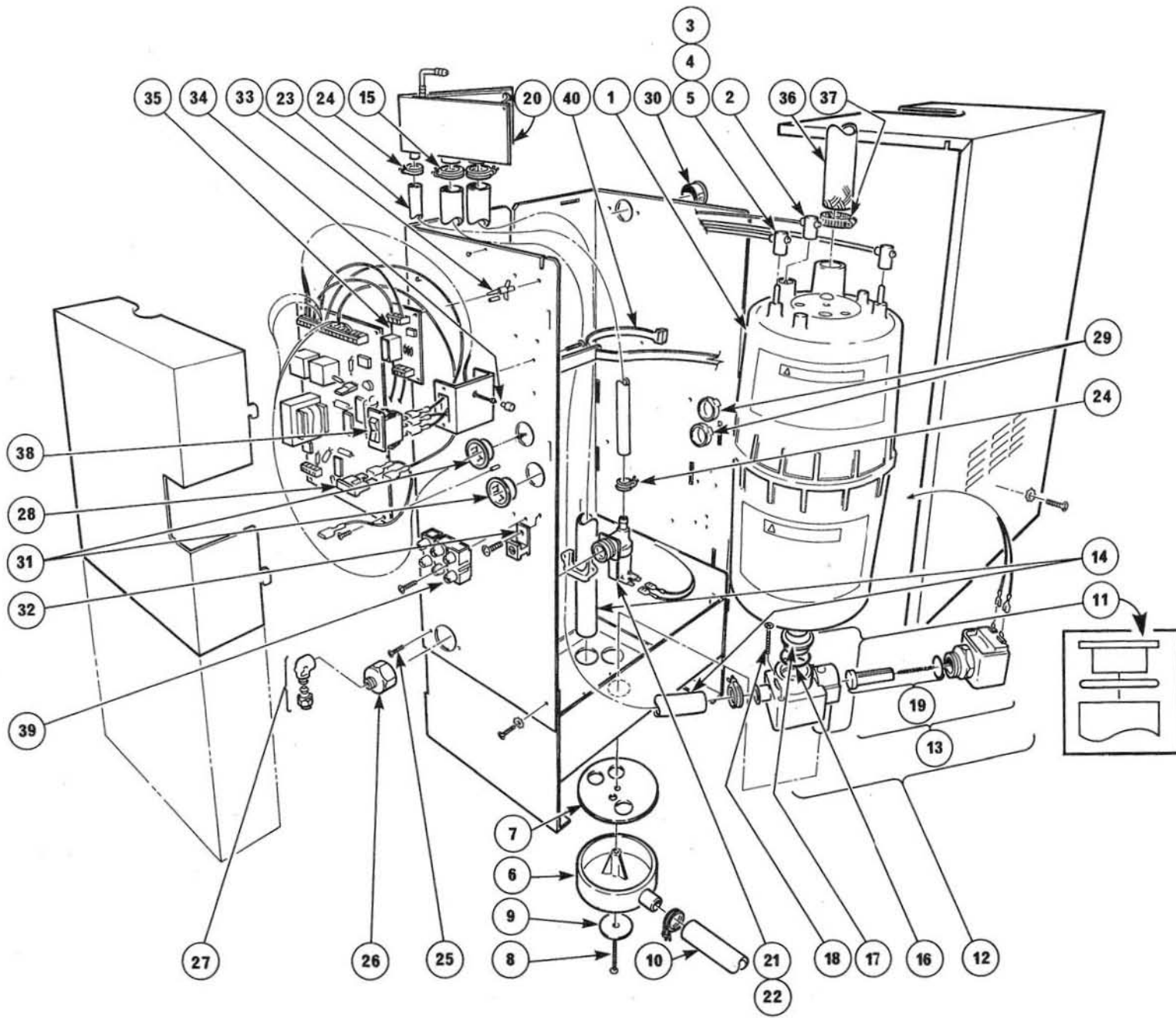

# LIMITED WARRANTY

---

Walter Meier Inc. and/or Walter Meier Ltd. (hereinafter collectively referred to as THE COMPANY), warrant for a period of two years from date of shipment, that THE COMPANY's manufactured and assembled products, not otherwise expressly warranted (with the exception of the cylinder) are free from defects in material and workmanship. No warranty is made against corrosion, deterioration, or suitability of substituted materials used as a result of compliance with government regulations.

THE COMPANY's obligations and liabilities under this warranty are limited to furnishing replacement parts to the customer, F.O.B. THE COMPANY's factory, providing the defective part(s) is returned freight prepaid by the customer. Parts used for repairs are warranted for the balance of the term of the warranty on the original humidifier or 90 days, whichever is longer.

The warranties set forth herein are in lieu of all other warranties expressed or implied by law. No liability whatsoever shall be attached to THE COMPANY until said products have been paid for in full and then said liability shall be limited to the original purchase price for the product. Any further warranty must be in writing, signed by an officer of THE COMPANY.

THE COMPANY's limited warranty on accessories, not of Walter Meier's manufacture, such as controls, humidistats, pumps, etc. is limited to the warranty of the original equipment manufacturer from date of original shipment of humidifier.

THE COMPANY makes no warranty and assumes no liability unless the equipment is installed in strict accordance with a copy of the catalog and installation manual in effect at the date of purchase and by a contractor approved by THE COMPANY to install such equipment.

THE COMPANY makes no warranty and assumes no liability whatsoever for consequential damage or damage resulting directly from misapplication, incorrect sizing or lack of proper maintenance of the equipment.

THE COMPANY retains the right to change the design, specification and performance criteria of its products without notice or obligation.



Walter Meier (Climate Equipment) Ltd.  
2740 Fenton Road, Ottawa, Ontario K1T3T7  
Walter Meier (Climate Equipment) Inc.  
826 Proctor Avenue, Ogdensburg, New York 13669  
Tel: 866 NORTEC 1 Fax: 613 822 7964  
nortec@humidity.com www.humidity.com

**walter  
meier**

PRINTED IN CANADA

