



NH Electrode  
Steam Humidifiers

---

# Installation, Operation, and Maintenance Guide

**IMPORTANT:** Read and save these instructions. This guide to be left with equipment owner.

# Table Of Contents

---

<b>INSTALLATION</b>	<b>1</b>
RECEIVING & UNPACKING EQUIPMENT . . . . .	1
PRE-INSTALLATION CHECKPOINT . . . . .	1
BASIC HUMIDIFIER CONFIGURATION . . . . .	1
LOCATION & MOUNTING . . . . .	2
HUMIDIFIERS . . . . .	2
BLOWER PACKS . . . . .	2
STEAM DISTRIBUTORS . . . . .	3
PLUMBING . . . . .	3
WATER SUPPLY LINE . . . . .	3
DRAIN LINE . . . . .	3
STEAM LINE AND CONDENSATE RETURN LINE . . . . .	4
ACCESSORIES - FILL CUP EXTENSION KIT(S) . . . . .	4
ELECTRICAL . . . . .	4
PRIMARY VOLTAGE SUPPLY WIRING TO HUMIDIFIER . . . . .	4
LOW VOLTAGE CONTROL WIRING . . . . .	5
On-Off Controls . . . . .	5
CONTROL INSTALLATION . . . . .	5
OPTIONAL MODULATION (CONTINUOUS CONTROLS) . . . . .	5
OPTIONAL MODULATION (CONTINUOUS CONTROL) PACKAGES BY NORTEC . . . . .	7
<b>OPERATION</b>	<b>7</b>
INTRODUCTION . . . . .	7
LAYOUT AND FUNCTION . . . . .	7
NHMC OPERATION . . . . .	8
START-UP SELF TEST . . . . .	8
USER LEVEL . . . . .	9
INFORMING THE USER . . . . .	9
SELF-HELP . . . . .	9
SYSTEM MESSAGES . . . . .	9
REMOTE INDICATION . . . . .	9
DOUBLE UNIT OPERATION . . . . .	9
NHB/NHP OPERATION . . . . .	9
END OF CYLINDER LIFE . . . . .	9
MANUAL CAPACITY ADJUSTMENT . . . . .	10
OTHER POTENTIOMETERS . . . . .	10
DETECTING WATER SUPPLY DEFICIENCY . . . . .	10
REMOTE INDICATION . . . . .	10
DOUBLE UNIT OPERATION . . . . .	10
BLOWER PACK OPERATION . . . . .	10

<b>MAINTENANCE</b>	<b>10</b>
WHEN TO REPLACE THE STEAM CYLINDER . . . . .	10
HOW TO REMOVE THE STEAM CYLINDER . . . . .	13
MANDATORY CLEANING OF THE DRAIN VALVE . . . . .	13
HOW TO INSTALL THE REPLACEMENT CYLINDER. . . . .	14
BUILT ON AND REMOTE MOUNTED BLOWER PACKS (BOBP'S / RMBP'S) . . . . .	15
<b>TROUBLESHOOTING</b>	<b>15</b>
STARTING POINT . . . . .	15
USING THE WIRING DIAGRAM . . . . .	21
TERMS USED . . . . .	22
WIRING DIAGRAM . . . . .	23-25
PRE START-UP CHECKLIST . . . . .	26
START-UP CHECKLIST AND QUICK REFERENCE. . . . .	27
MAINTENANCE CHECKLIST . . . . .	28-29
REPLACEMENT PARTS . . . . .	30-35

# INSTALLATION

## RECEIVING & UNPACKING EQUIPMENT

1. Check packing slip to ensure ALL material has been delivered.
2. All material shortages are to be reported to NORTEC within 48 hours from receipt of goods. NORTEC assumes no responsibility for any material shortages beyond this period.
3. Inspect shipping boxes for damage and note on shipping waybill accordingly.
4. After unpacking, inspect equipment for damage and if damage is found, notify the shipper promptly.
5. All NORTEC products are shipped on an F.O.B. factory basis. Any and all damage, breakage or loss claims are to be made directly to the shipping company.

## PRE-INSTALLATION CHECKPOINT

1. Ensure that available voltage and phase corresponds with humidifier voltage and phase as indicated on humidifier's nameplate label (see Figure #1).
2. Ensure that the dedicated external disconnect is of sufficient size to handle the rated amps as indicated on the nameplate label. Refer to local codes.

**Figure #1**  
**NH Series Humidifier**

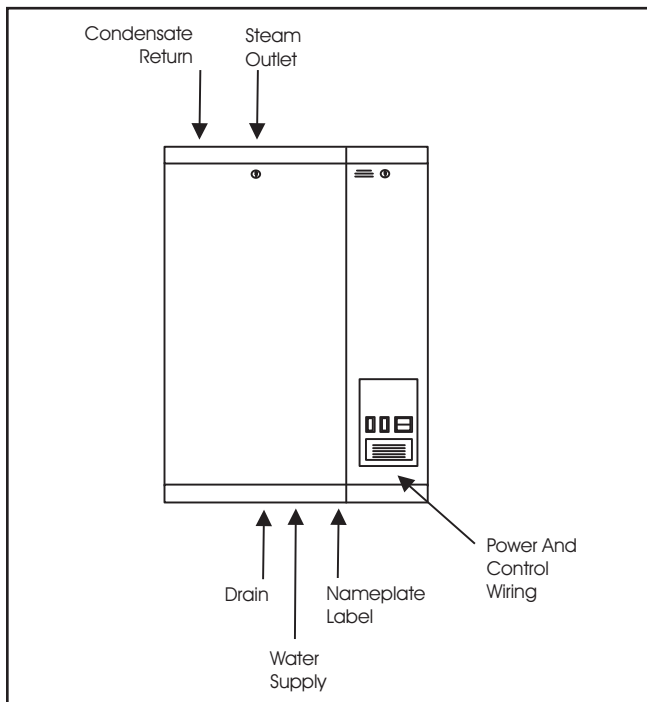

3. Report any discrepancy immediately.

## BASIC HUMIDIFIER CONFIGURATION

NORTEC humidifier models NHMC, NHP and NHB share a modular sheet metal cabinet. Each unit has a right side electrical compartment. Each electrical compartment has a hinge-down front door which is removable from any partially or fully opened position. Each electrical compartment has a screw-mounted right side cover which can also be removed for ease of electrical connection. For safety, the door when closed keeps the side cover from being removed.

Single units have a plumbing compartment attached to the left side of the electrical. Double units have a second plumbing compartment. Each plumbing compartment has a hinge-down front door which is not intended to be removed. For safety, the door must be closed in order to engage the shared lock. To avoid any danger, never operate the humidifier with a door off. For safety, each door when closed engages its own safety interlock switch. All switches must be engaged before the unit will operate.

To open the doors, unlock key, lift door up slightly and pull top of door forward. Door will hinge 180 degrees and hang straight down. To remove door, swing door parallel to floor. Then lift up slightly and out. To reinstall door, hold parallel to floor and insert hinge pins at bottom.

**Figure #2**  
**Clearance Requirements**

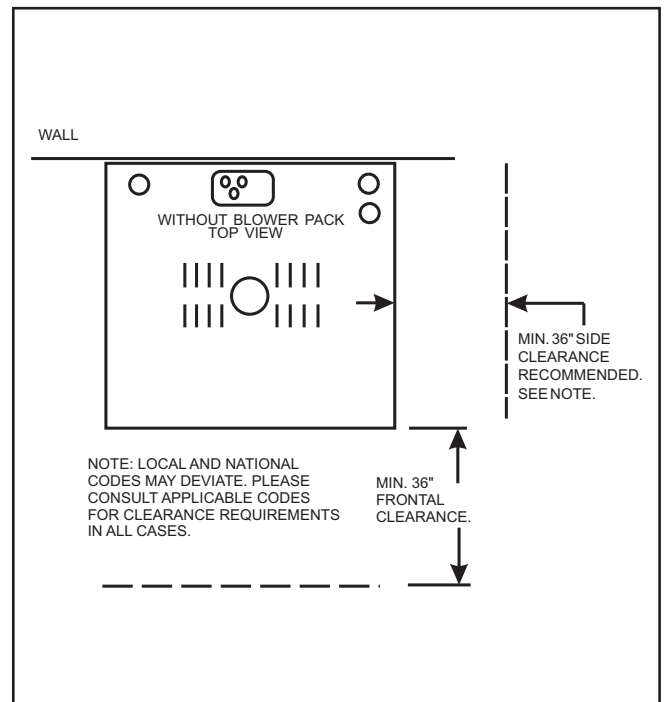

## LOCATION & MOUNTING

### HUMIDIFIERS

NH Series humidifiers are designed to mount on a suitable wall or vertical surface. Do not sit on floor due to clearances required for plumbing, electrical, and control entrances. The clearance dimensions shown in this manual are for reference only and are the minimum required for maintenance of the humidifier. Local and National Codes should be consulted prior to final location and installation of the humidifier. NORTEC can not accept responsibility for installation code violations.

1. Location of the humidifier should be below and as close as possible to the steam distributor location as possible.
2. For front and side clearance requirements (for access during installation, maintenance and troubleshooting), see Figure #2.
3. If possible, DO NOT locate humidifier any further than absolutely necessary from steam distributor location, as net output will be reduced as a result of heat loss through steam hose (see Engineering Manual, Form -163D). Also, increased static pressure may necessitate using an accessory fill cup extension kit.
4. Where possible, mount humidifier at a height convenient for servicing.
5. Wall mounting bracket provided should be securely attached horizontally and open edge upwards, using field-supplied fasteners. Use a minimum of 3 - #12 x 3" long wood screws, or

**Figure #3**  
**Wall Bracket Mounting Detail**

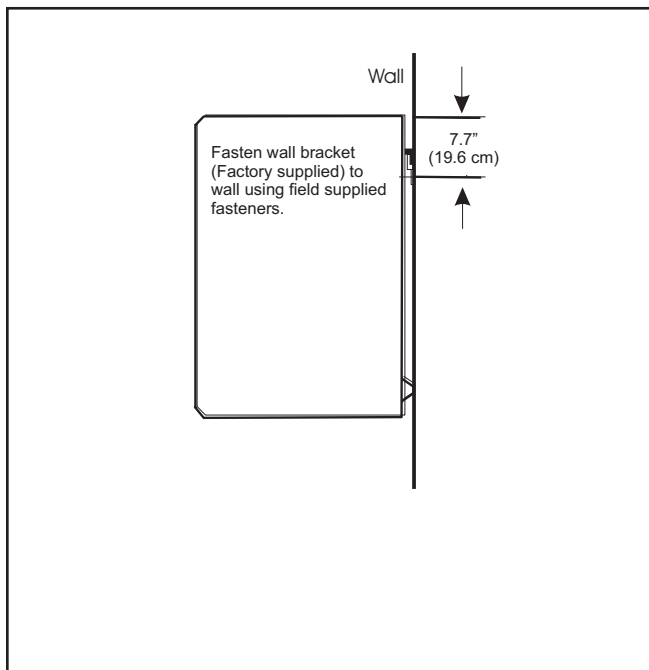

better, into a vertical structural surface. If any spacer material is used between the bracket and the structural material such as drywall, increase fastener length accordingly. In addition, install a minimum of 2 field supplied fasteners in the holes provided in the back of the unit to prevent the unit from being bumped off the wall bracket. See Figure #3.

6. Make sure humidifier is level.
7. DO NOT mount humidifier on hot surfaces.
8. If humidifiers are mounted on roof, a thermostatically ventilated weatherproof cabinet by others should be used. Consult factory.
9. DO NOT mount humidifiers in an area where freezing may occur. Use an accessory Low Temperature Protection Kit, if necessary.
10. DO NOT mount humidifiers on vibrating surface. Consult factory.

### BLOWER PACKS

1. Blower packs are an optional accessory used to directly distribute steam to localized areas (such as computer rooms) or in structures that do not have a built-in air distribution system.
2. Blower packs are available integrally-mounted on humidifier (built-on blower pack, BOBP, see Figure #4) or detached and field-piped and wired to humidifier (remote mounted blower pack RMBP, see Figure #5).

**Figure #4**  
**Built On Blower Pack (BOBP)**

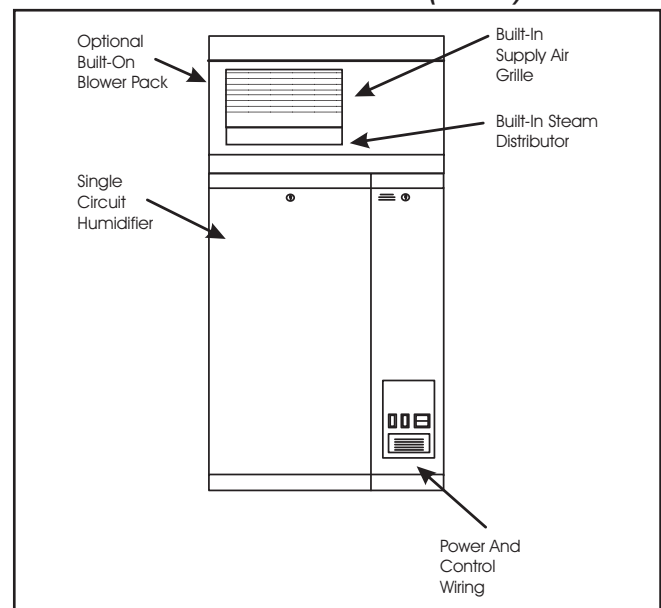

3. All NH Series blower packs consist of a steel cabinet containing: blower/motor powered by voltage directly from the humidifier, fuse, relay, speed select switch (in NH-050 and larger), stainless steel steam distributor, supply air grille with adjustable louvers, and built-in manual reset

**Figure #5**  
**Remote Mounted Blower Packs (RMBP)**

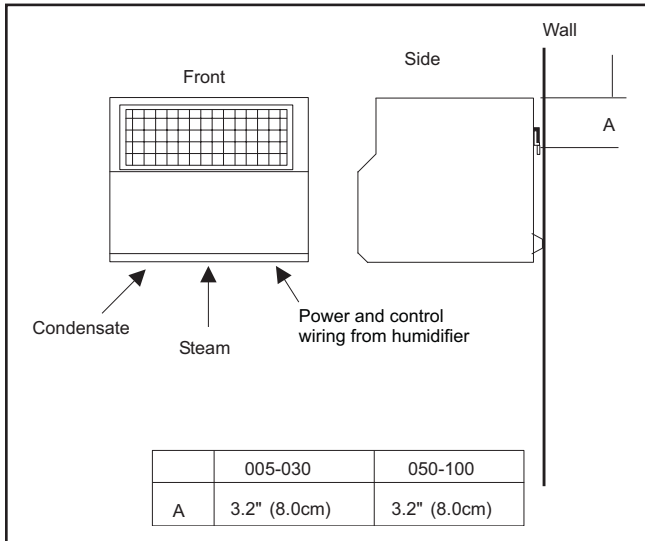

safety thermostat to turn off the humidifier if the blower pack gets overheated. Control thermostat, mounted on the steam distributor, starts the fan when steam is generated. When supply voltage differs from voltage required to run blower motor, blower pack will contain a proper transformer. All blower packs provide intake air filters.

For installation details about the blower pack, please refer to the blower pack installation manual located in the blower pack box (Form #XX-239).

### **STEAM DISTRIBUTORS**

1. Steam distributors are used in ducts or air handling units, and are made of stainless steel.
2. Steam distributors can be in vertical or downflow applications.
3. Proper location should consider: air temperature, relative humidity before the distributor, air velocity, dimensions of the location, amount of steam introduced into the duct, downstream obstructions, and surfaces vulnerable.
4. For installation details, please refer to steam distributor installation manual located in the distributor box (Form #XX-231).
5. For calculating absorption distances, refer to H.E.L.P. Software or steam distribution and absorption distances engineering manual (Form #XX-232).

### **PLUMBING**

**All water supply and drain line connections should be installed in accordance with local plumbing codes.**

### **WATER SUPPLY LINE**

1. Humidifier is intended to operate on potable (cold) tap water.
2. If the raw water is very hard, NORTEC can provide longer cylinder life on softened water. However, softened water is more conductive and more corrosive. Some hardware and/or software changes may be required, at time of order or in the field. Consult factory.
3. If RO or DI is available, blending may increase cylinder life. Consult factory.
4. **DO NOT** use a hot water supply to humidifier. Minerals will adhere more easily to surfaces and the fill valve's small flow regulating orifice and could become plugged.
5. Standard fill valves are sized for water pressure ranging from 30 to 80 psig (ideally 55 to 60 psig). For other pressures, consult factory. This pressure should be measured at the humidifier if the water pressure is suspect.
6. **ALWAYS** supply and install a shut off valve in the water supply line dedicated to the humidifier to facilitate servicing. Use 1/2" OD copper to within 4 feet of the humidifier. Reduce copper to 3/8" OD and connect to the factory-supplied 3/8" olive compression fitting under the humidifier.

### **DRAIN LINE**

1. Humidifier is equipped with a 7/8" O.D. unthreaded drain outlet on underside of drain canal on bottom of the humidifier (see Figure #6). A field-supplied funnel (see Figure #7) is recommended. It will prevent backup in the drain pan and in the cylinder due to partially blocked or badly installed drain lines. This prevents rusting of the drain pan and arcing due to over-concentration. The drain canal

**Figure #6**  
**Drain Line Connection**

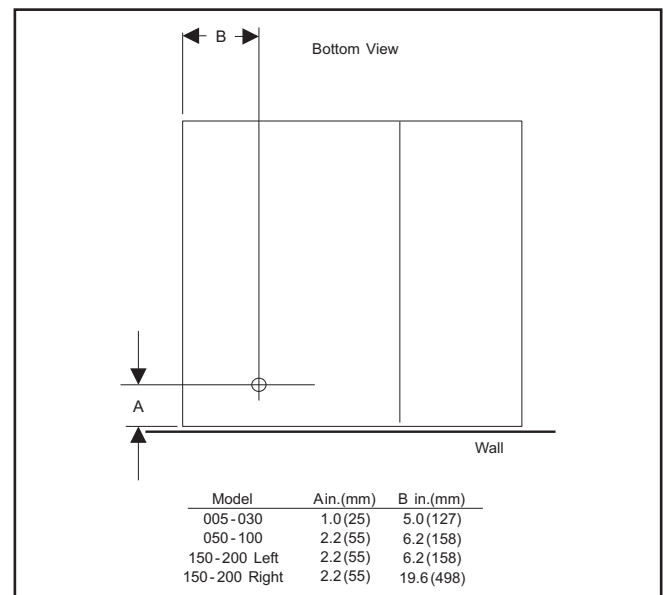

has been improved to prevent backup despite long or gently sloped drain lines but it can not compensate for flat or uphill runs.

2. The drain line should not end in a sink used frequently by personnel, or where plumbing codes prohibit it. Route to a floor drain or equivalent for safety reasons, since drain water from humidifier can be very hot.
3. Keep drain lines as short as possible. **Keep drain lines sloped down, not level and not up since low spots in drain lines will accumulate sediment and cause backup.** The drain line should be 7/8" O.D. copper pipe or larger. Do not use plastic pipe for drain lines. Consult factory.

**Figure #7  
Drain Connection**

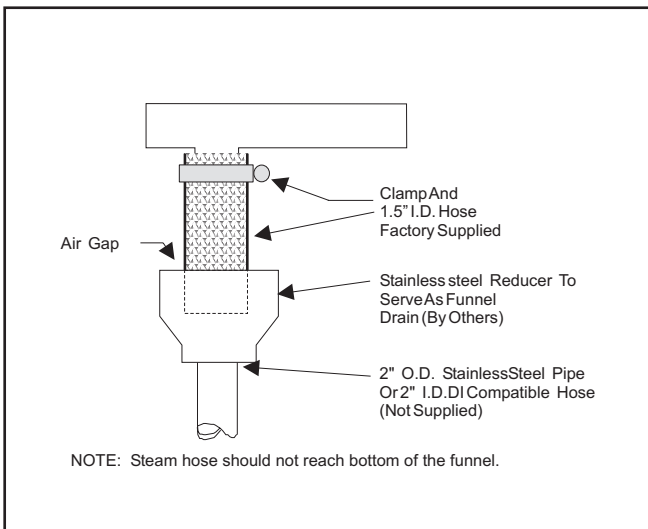

**STEAM LINE AND CONDENSATE RETURN LINE**

1. Refer to the installation manual of the steam distribution system used in your application. Steam Distribution - Form #XX-231, SAM-e - Form #XX-249, Blower Pack - Form #XX-239.

**ACCESSORIES - FILL CUP EXTENSION KIT(S)**

1. The NH Series humidifier is an electrode humidifier. It produces steam at atmospheric pressure. Pressure head must develop to push steam through supply line and into air duct.
2. Combined resistance of duct positive static pressure and steam line resistance creates a small pressure head in steam cylinder. Total amount of positive static pressure head is reflected directly by water column differential that develops between water in the fill cup hose feeding cylinder and water level in cylinder.
3. Standard dimensions of humidifier limit static that can be tolerated before water will be pushed high enough to spill over into overflow tube in fill cup assembly.

4. To increase allowable water column (allowable positive static pressure) an accessory Fill Cup Extension Kit is available from NORTEC. See Figure #8.

**Figure #8  
Fill Cup Extension Kit to Overcome Static Pressure**

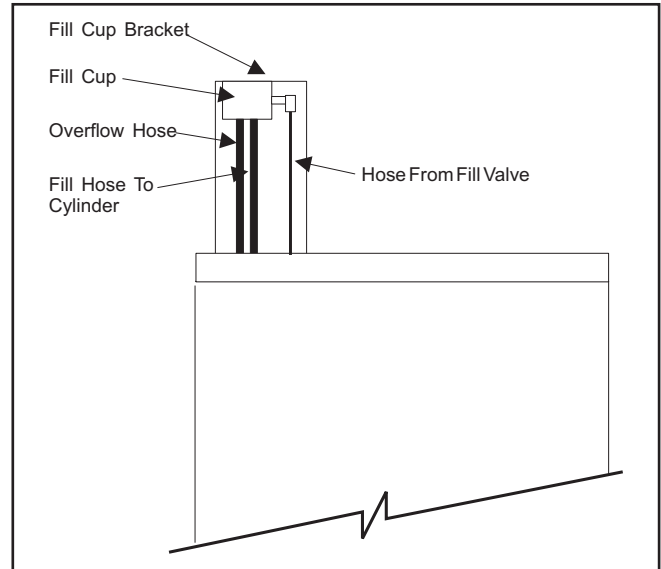

5. Water column requirements are even higher duct static pressure when distributor's steam outlets are faced with downflow duct applications.

**ELECTRICAL**

**PRIMARY VOLTAGE SUPPLY WIRING TO HUMIDIFIER**

1. Check and ensure that available voltage and phase corresponds with operating voltage and phase of humidifier as indicated on the humidifier nameplate label (see Figure #1).
2. Ensure that an adequate power supply is available to carry full humidifier amperage drawn as specified by rated amps on the humidifier nameplate label refer to local codes.
3. A dedicated external disconnect must be installed. Do not exceed the maximum circuit protection amps as indicated on the nameplate label.
4. Optional internal primary fuses are not intended to substitute for external fuses. Internal primary fuses are a factory added option (when specified) to protect internal primary wires individually.
5. Connect ground wire to cabinet ground clamp. Do not use neutral wire of four wire supply as ground.
6. Single phase humidifiers may be run on three phase power, but load may unbalance power grid.
7. External wiring sizes must be in accordance with NEC and/or CEC and existing local electrical codes and by-laws.

## LOW VOLTAGE CONTROL WIRING

### On-Off Controls

**Figure #9**  
**External Wiring of On/Off Controls**

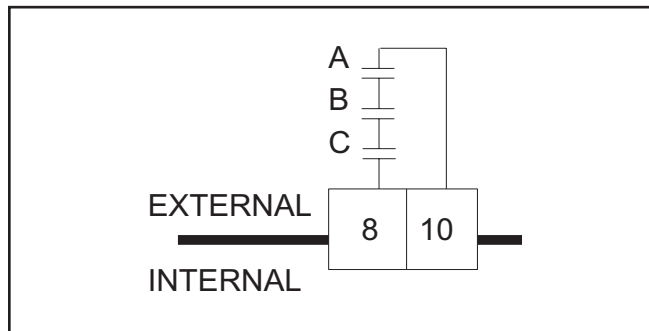

Controls are available from NORTEC as accessories. If controls were not ordered with humidifier, they must be purchased supplied by others. The following information is relevant to all controls, factory supplied or otherwise.

A, B and C (described below) are to be wired in series (only one path for current) across terminals 8 and 10 on the low voltage control terminal strip, or replaced with a jumper wire for constant operation. Caution: this is the "hot" wire from the 24V control transformer; it will blow the 3A fuse if any control field wiring touches ground metal.

#### **A - Wall or Duct Mounted Control On/Off**

**Humidistat:** Wired to make on drop in humidity, break on rise to setpoint. Set to desired % RH. Can be a make/break set of contacts from a Building Automation System.

#### **B - Duct Mounted Safety High Limit On/Off**

**Humidistat (if used):** Wired to make on drop in humidity, break on rise to safety setpoint. Set to approximately 85% RH as a safety to help prevent saturation and wetting in the duct.

#### **C - Duct Mounted Safety Air-Proving On/Off**

**Switch (if used):** Wired to make when sensing air flow, break when no air flow. Used as a safety to prevent saturation when no air flow.

1. NORTEC offers various versions of A, B and C to suit each application. In general, A is essential, whereas B and C are highly recommended in ducted applications.
2. Field wiring from humidistat to humidifier and between devices should be 18 AWG or heavier and kept as short as possible.
3. Low voltage control terminal strips are provided in the electrical compartment. Internal sides are factory wired. External sides are to be field wired.

4. Each humidifier is supplied with a wiring diagram inside.

## CONTROL INSTALLATION

1. Mount any **wall humidistat** (control or high limit) over standard electrical box at height similar to typical thermostat. Any **wall humidistat** should be in location representative of overall space being humidified and not in path of blower pack or air supply grille. Do not mount on a outside wall where temperature fluctuation can affect control response.
2. Mount **duct humidistat** in location representative of overall air humidity, usually return duct. Do not mount it directly in front of steam distributor or in turbulent or mixing zone. Mount it where air's humidity and temperature are uniform and representative of spaces being humidified.
3. Mount **duct high limit humidistat** downstream of steam distributors far enough that, under normal humidity and air flow conditions, steam will have been fully absorbed (typically at least 10 feet). It must be located to sense high humidity only when uniform and representative air is over-humidified or approaching saturation.
4. Mount **duct air-proving switch** so that it is able to sense air flow or lack of it. Wire it to make when air flow is sensed and break when air flow fails.
5. Check operation of all on/off controls before starting humidifier.
6. Calibration of controls (on/off or modulation) in the field may be necessary due to shipping and handling. Verify humidistat accuracy before commissioning system.

## OPTIONAL MODULATION (CONTINUOUS CONTROLS)

1. Read **on/off controls** section first since it is necessary to all control systems.
2. Virtually any modulation (continuous control) external hardware by others (as long as it has %RH setpoint circuitry) may be interfaced with pre-specified factory-configured NHMC/NHP Series pc board via the control terminal strip. The NHB can be used with on-off control only. Use shielded cables for modulation circuits.
3. Modulation (continuous control) by others for use with NHMC/NHP Series humidifiers involves one of several control wiring diagrams. In all cases, modulating signal interfaces through control terminal strip to main pc board inside humidifier.
4. The modulation signal must increase from minimum toward maximum as sensed RH (actual RH) drops below desired RH (%RH setpoint). In response, humidifier's steam output will increase from minimum toward maximum. When humidifier's steam output (lbs/hr) matches humidification load (lbs/hr), modulation signal will stabilize.

**Figure #10**  
**Primary Voltage Supply Wiring**

VOLTAGE  
(ACTUAL)

PRIMARY (LINE) VOLTAGE WIRING TO UNIT  
(BY OTHERS)

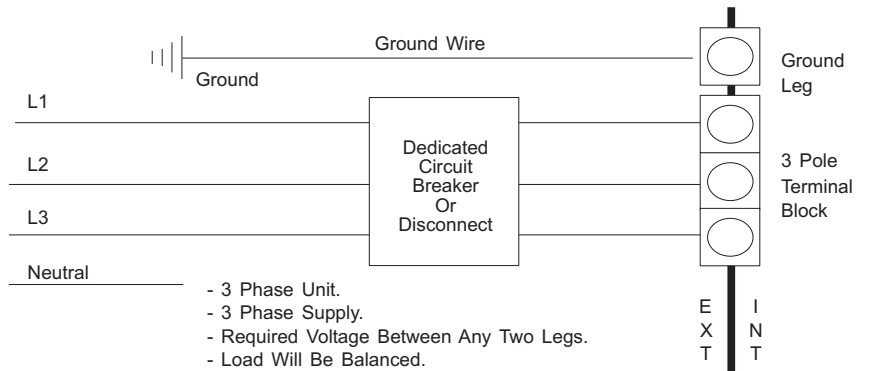
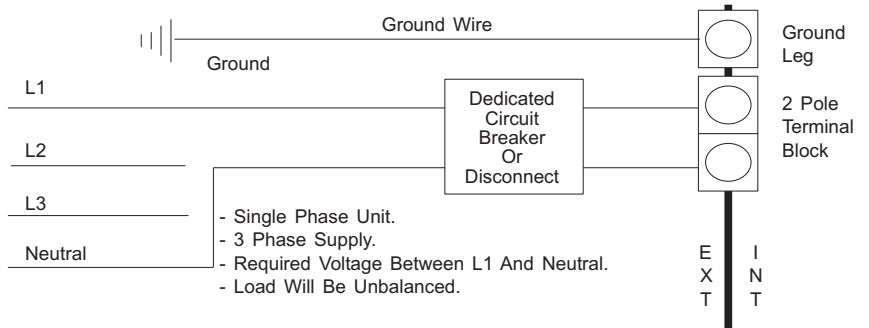
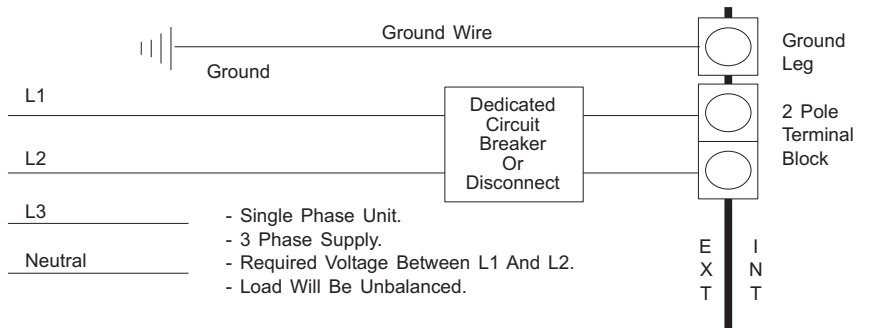
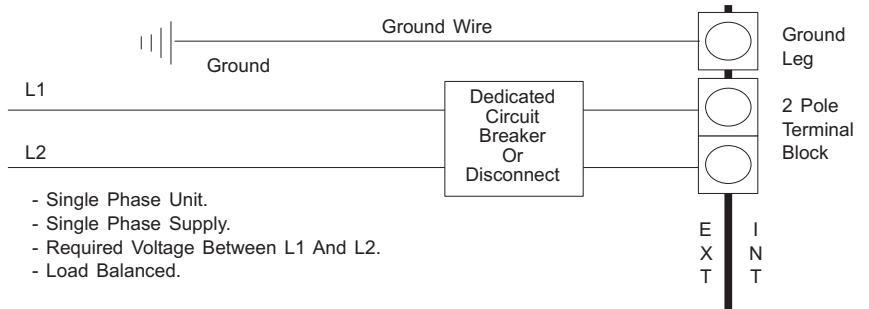

NOTE: Voltage At Terminal Block Must Be In Accordance With Spec. Label.  
All Wiring To Be In Accordance With Existing National And Local Electrical Codes.

5. Field-wiring connections for modulation control are to be made to external side of terminals 26, 28, 30 and 32 on humidifier's control terminal strip. Always refer to the external control's wiring diagram factory supplied with each NORTEC modulation control option.
6. **Varying dc Voltage Modulation Signal Powered by Others:** NHMC/NHP Series humidifier can be factory configured to accept the following vdc signals: 0-3 vdc, 0-10 vdc, 0-16 vdc, 0-20 vdc, 1-5 vdc or 2-10 vdc. Wire according to NORTEC supplied external wiring diagram that comes with each modulation option. To share the signal with more than one humidifier, wire in parallel to each humidifier. If a different signal is desired consult factory.
7. Varying dc milliAmp (mA) Modulation Signal Powered by Others: NHMC/NHP Series humidifier can be factory-configured to accept a standard dc mA signal, if pre-specified. Wire according to NORTEC supplied external wiring diagram that comes with each modulation option. Choose from 0-20 dc mA or 4-20 dc mA. To share the signal with more than one humidifier consult factory.
8. Varying Resistance ( $\Omega$ ) Modulation by Others: NHMC/NHP Series humidifiers can be factory configured to power a 3-wire varying resistance modulation humidistat by others, if pre-specified. Wire according to NORTEC supplied external wiring diagram that comes with each modulation option. Choose from 0-135 $\Omega$ , 0-500 $\Omega$  or up to 0-1000 $\Omega$ . To share the signal with more than one humidifier consult factory.

**OPTIONAL MODULATION (CONTINUOUS CONTROL) PACKAGES BY NORTEC**

1. Modulation (continuous control) "packages" are offered as accessories by NORTEC. Power supply comes from inside NHMC/NHP Series humidifiers.

**Figure #11  
Generalized Modulation Wiring**

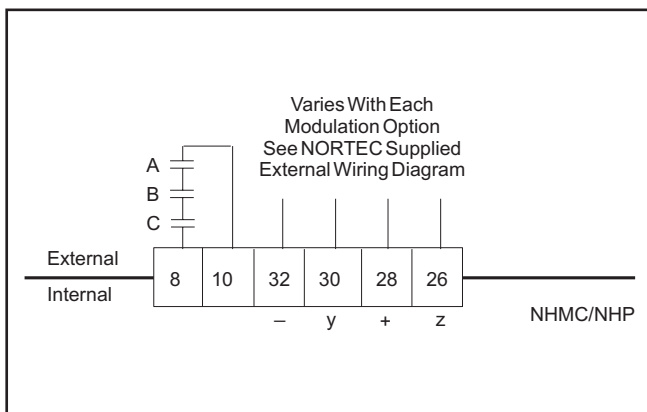

2. NORTEC provides the humidity set point circuitry and sensor(s) for wall or duct mounting or both (only applies to NHMC. NHP is only capable of single channel continuous control modulating) as

pre-selected when ordering the option. NORTEC offers several packages for NHMC/NHP Series humidifiers. Wire according to NORTEC supplied external wiring that comes with each optional modulation package.

3. Optional modulation packages without modulating safety high limit can use on-off safety high limit. Refer to on-off controls section.
4. All versions can use on-off safety air proving switch. Refer to on-off controls section.

## OPERATION

### INTRODUCTION

The NORTEC NH Series humidifier is a completely new design based on up-to-date technology. The NHB is designed to provide clean steam humidification at an economical price. It utilizes NORTEC's patented electronic Auto-Adaptive internal control system for high efficiency, low waste of water and electricity.

The NHP and NHMC utilize NORTEC's patented P+I Auto-Adaptive control for greater control of the space humidity. Both the NHP and NHMC use a micro-computer control system for greater flexibility. The NHMC has a liquid crystal display (LCD) to indicate system messages, display RH and temperature. The NHMC can accept dual modulation signals and is NORTEC's most advanced model.

### LAYOUT AND FUNCTION

The NH Series humidifiers consist of a plumbing and an electric compartment. In every case there is at least one steam distributor (SD) for installation in air ducts or blower packs (built on: BOBP, remote mounted: RMBP) for direct space humidification.

Water enters the steam cylinder through the bottom via the drain valve from the fill cup assembly when the 24 volt fill valve solenoid is energized. When water submerges the electrodes, the minerals in the water conduct current that heats the water and produces sterile steam for distribution into the air. The minerals in the water remain in the cylinder which is periodically drained to maintain optimum performance and cylinder life.

Primary electric power is applied to the electrodes in the steam cylinder when the on/off switch is pushed on and all controls options are calling. A primary to 24 volt stepdown transformer provides power to the contactor holding coil(s) via the main control board. The humidifier's operating status is reported to the user by the green and yellow indicator lights on the front of the unit as shown in following table.

SIGNAL LIGHT STATUS		
YELLOW	GREEN	
OFF	OFF	Off
OFF	ON	Normal operation
ON	ON	Replace cylinder or normal startup operation
ON	OFF	Operation fault

The prerequisites for getting power and water into the steam cylinder are as follows:

- on/off/drain switch must be switched on
- control circuit 8-10 must be made
- modulation humidistat, if present, must be calling
- control circuit 82-83 must be made
- control circuit 84-85 must be made
- cabinet mounted humidistat, if present, must be calling
- door interlock switch must be made (interlock switch can be pulled out to operate unit)

Most water does not contain enough conductivity for full boil on initial start-up. Units will need to concentrate the water over a time period (hours to days). During this process both lights are on.

## NHMC OPERATION

### START-UP SELF TEST

Observe the LCD display when the on/off/drain switch is first pushed on. The microcomputer pc board will check the system components, display in words what it is doing and provide a message if any faults are found. The start-up self-test sequence will be displayed as follows:

LCD	EXPLANATION/COMMENTS (WHAT YOU READ)
CONDAIRMATIC MC	Note the V number. It tells you the EPROM version.
NORTEC V2...	
CONDAIRMATIC MC	Note the model type. Ensure NHMC (model type) compatibility with spec label (name plate). Can be reconfigured if necessary.
SYSTEM TEST	Test begins.
LAMP GREEN	Observe green signal light on
LAMP YELLOW	Observe yellow signal light on
CONTACT RELAY 1	Provides 24 VAC to 61-20 and external optional yellow lamp at control strip to simulate a fault.
DRAIN VALVE	Observe 24 volt solenoid activated on drain valve.
INLET VALVE	Observe 24 volt solenoid activated on fill valve.
CONTACTOR	Observe 24 volt coil activated on contactor OR fan activated on blower pack if present.
CONTACT RELAY 2	Provides 24 VAC to 63-36 and external optional red lamp at control strip to simulate cylinder spent.
CONTACT RELAY 3	Provides 24 VAC to 62-40 and external optional green lamp at control strip.
INTERNAL TEST	Completion of self test.
LAMP GREEN-YELLOW INTERNAL TEST	Observe green and yellow lamps pulse on together as sign that all passed.
STEAM OUTPUT INTERNAL TEST	Begins normal operation and displays lbs/hr.
NOTE: If cylinder water reaches the full cylinder sensor, the LCD will read "MAXIMAL LEVEL".	

## **USER LEVEL**

The keypad has four keys: MENU, ↑, ↓, ENTER.

Each time the user presses the menu key, the microcomputer will display on the LCD the next operating parameter on the menu. The basic display will read:

- Steam output (lbs/hr)
- Capacity demand
- Limited capacity
- Control signal y

The display loops back to the top of the menu the next time the user presses the menu key. As NORTEC software updates are incorporated, new parameters will automatically be added to the menu.

## **INFORMING THE USER**

The microcomputer continually monitors the operating status and informs the user in four ways. The first (signal light status), second (optional external lamps tied to the control strip) and third (operating parameters displayed on the alphanumeric LCD display) have been discussed. The fourth way is to interrupt the LCD and display a system message. It only does this as a last resort.

## **SELF-HELP**

The microcomputer applies corrective actions whenever its self-diagnostics identifies a problem that it is able to correct by itself. If the corrective action is not successful then it displays a system message. If the corrective action requires a service person, then the microcomputer's only resort is to stop the unit and display a system message. The unit never stops unless it has to.

After three days of no call from either the on/off controls or the modulating controls, the drain valve is automatically activated long enough to drain all water from the steam cylinder. This NORTEC exclusive feature will prolong the life of the cylinder.

## **SYSTEM MESSAGES**

Alphanumeric system messages will appear on the LCD display any time the microcomputer decides the user must be informed. The microcomputer does not stop the unit for all system messages. (See the Troubleshooting Section in this manual)

## **REMOTE INDICATION**

The NHMC is always internally wired to provide 24 VAC to the terminal strip for optional external remote indication. Up to 100 milliamps is available at each of three terminal pairs (61-20, 62-40, 63-36) for activating yellow, green and red lamps ordered as options from NORTEC or for powering field-supplied resistive loads such as lamps.

## **DOUBLE UNIT OPERATION**

Turn both switches on. During start-up self test both sides respond to the self test together. Watch for the lamps to light and the drain, fill and contactor to energize as described on page 15. The LCD, however, only indicates the left circuit [1].

After the self test, the LCD will display the steam output for the left side [1] and both sides will operate normally.

To alternate between parameters for the left side [1] and parameters for the right side [2], press the Enter key.

Use the MENU key to see other parameters besides steam output. To display steam total output for both sides press the enter key until [Σ] is displayed.

When a fault occurs on the right side of the double unit, both sets of lamps (and remote relays) will come on indicating that a fault has occurred. The left [master] will display its own faults.

The LCD will indicate which fault has occurred and on which side of the unit, [1] or [2]. The side not faulted will continue to operate as usual.

Display is not available for the right side [2] if the left side is switched off.

## **NHB/NHP OPERATION**

### **END OF CYLINDER LIFE**

When the cylinder is used up and water level can no longer stabilize below full cylinder (due to fully coated electrodes), the yellow light will come back on, in addition to the green light. The disposable cylinder must be replaced.

Although "both lights on" is the same signal at start-up as it is at end of cylinder life, the age of the cylinder enables the user to know when "both lights on" is indicating end of cylinder life. It is wise to keep a new replacement cylinder on hand to avoid downtime when it becomes time to change the disposable cylinder. (See Troubleshooting section.)

## **MANUAL CAPACITY ADJUSTMENT**

The NHB humidifier is rated in lbs/hr of steam output capacity. Set to 100%, it will operate at full output until the humidistat has sensed that the humidity has reached setpoint. Then it will stop the humidifier by breaking control circuit 8-10.

If the humidifier is oversized, the humidistat will be quickly satisfied and stop the humidifier. As humidity level drops the humidistat calls again. It is quickly satisfied and stops again. The resultant short-cycling is easily overcome.

A manual capacity adjustment potentiometer ("pot") is provided on the NHB main pc board for that purpose. It is marked "Sx%" and is adjustable from 20 to 100% of rating.

The NHP humidifier, utilizing modulation control, does not have the same problems of oversizing. It reacts to the modulation signal and varies its capacity automatically. However, if you wish to turn down the capacity, the NHP has the same manual capacity adjustment potentiometer ("pot") that the NHB has.

## **OTHER POTENTIOMETERS**

Do not adjust any other potentiometers ("pots") on the pc board(s). They are factory-set and not meant to be user-set.

## **DETECTING WATER SUPPLY DEFICIENCY**

Knowing how long it normally takes to fill each size steam cylinder, each humidifier's pc board is factory configured to an acceptable maximum filling time (using jumpers). If it is filling too slowly, when the time expires the electronics stops the humidifier. To indicate this, the green light goes out and the yellow light goes on.

## **REMOTE INDICATION**

Every NHB/NHP comes factory wired to provide 24 VAC (100 mA max.) at 61-20 on the control terminal strip. The user can connect an indicator externally to 61-20. It will automatically be activated any time the yellow light is on. It will therefore be activated whenever the humidifier shuts off due to excess current or water deficiency. It is also normal for it to be activated on start-up.

## **DOUBLE UNIT OPERATION**

Turn both switches on. If there is a demand for humidity, the green status lamp will indicate that the circuit is operating.

On the NHP, the optional output indication meter will steadily increase until the meter reads maximum output. Maximum output depends on the manual capacity setting of the unit and/or the continuous control demand.

The NHB/NHP has built in diagnostic capabilities and will shutdown for the following reasons:

- No current (similar to NHMC Error Message 5).
- Excess current (similar to NHMC Error Message 1).
- Change cylinder/end of life (similar to NHMC Error Message). NHB will shutdown on this fault.

In all cases, when an error is detected, there will be 24 VAC potential (100 mA max.) available at terminals 20 and 61 of the internal external white terminal strip.

## **BLOWER PACK OPERATION**

Blower packs are equipped with a control thermostat mounted on the steam distributor. As soon as humidifier generates steam, the contact is closed and the fan is started. When steam is no longer being generated, the fan cuts out with a delay.

If blower packs get overheated (malfunction of the air circulation), the manual reset safety thermostat interrupts the steam generation. To reset, switch off the humidifier and wait until the steam distributor cools down. Then remove left-hand side intake air filter and, using a screwdriver, press the reset button (marked with a red dot) inside the blower packs.

Units are equipped with speed select switch. The switch is located on the right-hand side of the blower, inside the blower pack. To access the switch, remove right-hand side intake air filter.

To avoid condensation on the cabinet parts, run blower pack on high speed when humidifier delivers 75 lbs/hr or 100 lbs/hr of steam.

# **MAINTENANCE**

**WARNING!** The plumbing and electrical compartments contain high voltage components and wiring. The access door(s) is equipped with a lock. Access should be limited to authorized personnel only.

## **WHEN TO REPLACE THE STEAM CYLINDER**

The steam cylinder is disposable and must be replaced at end of cylinder life. Cylinder life is

dependent on water supply conditions and humidifier usage. Failure to replace the cylinder at the end of cylinder life may result in unit damage. NORTEC is not responsible for any damages resulting from, or attributable to, the failure to replace a used cylinder (see Manufacturer's Warranty). There are many indications, each of which signifies the end of cylinder life.

### **NHMC**

1. After a period of operation (not on initial start-up), the water level will approach the top of the cylinder. (Life varies from 500 to 2000 operating hours, as illustrated in Figure #12.)

**Figure #12**  
**Water Conditions vs. Cylinder Life**

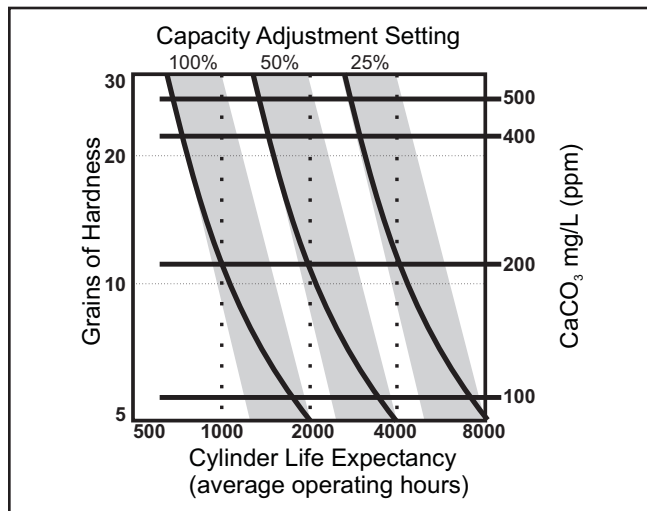

2. There will be reduced output in spite of a 100% capacity setting and/or an unsatisfied demand from the humidistat for more humidity. This is evident by monitoring the unit's output on the LCD (liquid crystal display) with up to two lines of continually updated alphanumeric information for the user.
3. Each NHMC humidifier has an internal micro-computer that can detect end of cylinder life. If the cylinder is not changed, the humidifier will automatically shut down.
4. The unit's yellow status lamp is activated anytime there is a system message sent to the LCD where two lines of alphanumeric information await the user. System messages are explained in greater detail later in this manual. Three (3) different messages will appear, in sequence, as the cylinder goes from new to spent to needing replacement.
5. The NHMC is pre-programmed to inform the user of the cylinder's status. It is important to understand the significance of the unit's system messages, status lamps and 24VAC circuits for remote indication. Figure #2 summarizes these messages and responses.

6. The three (3) messages that will appear in sequence are "MAXIMAL LEVEL", then "CYLINDER SPENT", and finally "CYL. LIFESPAN END". The yellow unit status lamp will be on during all three.
7. The green unit status lamp, primary contactor and steam output will stop at "CYL. LIFESPAN END". This distinguishes it from "MAXIMAL LEVEL" and "CYLINDER SPENT".
8. Each of these three (3) messages has a unique combination of responses at the terminal strip for remote indication. These unique combinations distinguish them from each other and from any other system message.
9. At "MAXIMAL LEVEL" remote yellow-green-red are OFF-ON-OFF. (Note that "MAXIMAL LEVEL" will also appear at unit start-up.)
10. At "CYLINDER SPENT" remote yellow-green-red are OFF-ON-ON. In other words, the red comes on as the cylinder ages from "MAXIMAL LEVEL" to "CYLINDER SPENT". This gives the user ample warning (remote red on) to replace the cylinder before the NHMC shuts itself down.
11. At "CYL. LIFESPAN END" remote yellow-green-red are ON-OFF-ON. In other words, the remote green goes off and the remote yellow comes on in addition to the red if "CYLINDER SPENT" remains unchanged for approximately three (3) days.
12. The NHMC is always internally wired to provide 24VAC to the terminal strip for optional external remote indication. Up to 100 mA is available at each of three terminal pairs (61-20, 62-40 and 63-36) for activating yellow, green and red optional external remote indicators, respectively. Any or all of these remote indicators can be utilized. They can be field-supplied resistive 24 VAC loads such as lamps or ordered as options from NORTEC.

### **NHB/NHP**

1. There will be reduced output in spite of a 100% capacity setting and/or an unsatisfied call from the on/off humidistat for more humidity. The NHP has an output display where you will observe that the capacity of the unit is decreasing.
2. Each NHB/NHP humidifier has a yellow status lamp, a green status lamp, and a relay for remote indication. Double units (models NH 150-200) have two of each.
3. The yellow and green status lamps are long-life LED's (light emitting diodes) not incandescent lamps.
4. The yellow and green status lamps are to be viewed as a pair. This way, they convey four

**Figure #13**  
**System Messages and Responses (EPROM : 2.XXN)**

NHMC						
SYSTEM MESSAGE DISPLAYED ON LCD	UNIT CONTACTOR	UNIT STATUS LAMPS		REMOTE INDICATION (24 VAC TO:)		
		YELLOW	GREEN	61-20 "YELLOW"	62-40 "GREEN"	63-36 "RED"
Maximal Level	ON	ON	ON	OFF	ON	OFF
Excess Current / Error 1	OFF	ON	OFF	ON	OFF	OFF
No Current / Error 2*	OFF	ON	OFF	ON	OFF	OFF
Max. Filling Time / Error 3	OFF	ON	OFF	ON	OFF	OFF
Cylinder Spent / Error 4	ON	ON	ON	OFF	ON	ON
No Current / Error 5	OFF	ON	OFF	ON	OFF	OFF
Output Too Low / Error 6	OFF	ON	OFF	ON	OFF	OFF
Electronic / Error 7	OFF	ON	OFF	ON	OFF	OFF
Phase Interrupt / Error 8	ON	ON	OFF	OFF	OFF	OFF
Cyl. Lifespan End / Error 9	OFF	ON	OFF	ON	OFF	ON

\* When No Current/Error 2 is displayed, display will change to show Maximal Level and will alternate back and forth.

NHP				
SYSTEM FAULTS*	UNIT CONTACTOR	UNIT STATUS LAMPS		REMOTE INDICATION (24 VAC TO:)
		YELLOW	GREEN	"YELLOW" 61-20
Maximal Level	See NHMC Chart above for details			
Excess Current	OFF	ON	OFF	ON
No Current	OFF	ON	OFF	OFF
Max. Filling Time	OFF	ON	OFF	ON
Cylinder Spent	ON	FLASHING	ON	OFF
No Current	OFF	ON	OFF	OFF
Output Too Low	OFF	ON	OFF	OFF
Electronic	N/A	N/A	N/A	N/A
Phase Interrupt	N/A	N/A	N/A	N/A
Cyl. Lifespan End	OFF	FLASHING	OFF	ON

\*NOTE: NHP does not display actual message or error.

- Remote indication 61-20 "yellow" means humidifier has shutdown and one of several system messages is showing. The exception is on the NHP when No Current or Output Too Low is the fault, 61-20 "yellow" will be off, but the yellow light on the NHP will be on.
- Remote indication 62-40 "green" means contactor is on; humidifier is operating.
- Remote indication 63-36 "red" means cylinder is spent; replacement is necessary.

messages, instead of two, as summarized in Figure #14.

**Figure #14**

YELLOW	GREEN	
OFF	OFF	Off
OFF	ON	Normal operation
ON	ON	Replace cylinder or normal start-up operation
ON	OFF	Operation fault

- When both the yellow and the green status lamps are on, the water level is detected as being at the top of the cylinder. This is normal on start-up, but as the contained water concentrates, the water will stabilize at a lower water level and the yellow lamp will be off.
- When the cylinder is fully used, the water level will have returned to the top of the cylinder. Since there is no longer any clean electrode surface available at end-of-cylinder-life, the required steam output rate can no longer be maintained.
- At this stage, the yellow lamp flashes and the green lamp is on, telling the user that the cylinder is reaching the end of its life and will need to be replaced shortly. The humidifier continues to operate.
- The NHB relay for remote indication is not intended to indicate end-of-cylinder-life. It is intended to indicate other detected faults explained later in this manual.
- The NHP at end of cylinder life will not operate, the yellow lamp will "flash", and the green lamp will be "off".

## HOW TO REMOVE THE STEAM CYLINDER

- (It is advisable to keep a spare cylinder in stock throughout the humidification season.) When ordering a replacement steam cylinder, always quote the three or five digit model number on the label applied to the cylinder or quote the unit's serial number, model and voltage located on the spec label (nameplate).
- Turn off water supply to unit.
- The used cylinder must be drained completely before removal. If the water has just been boiling, allow it to cool before draining. Push the ON/OFF/DRAIN switch to the MANUAL DRAIN position. Leave it in this position just long enough to drain the cylinder (usually less than 10 minutes).
- When completely drained, push the main ON/OFF/DRAIN switch back to the OFF position.

- Once drained, open the main electrical disconnect during the entire cylinder change operation.
- Open plumbing door.
- Cylinder plugs are attached to the primary voltage cylinder wires. (The plugs remain attached to the wires unless they have to be replaced due to damage.) The plugs are press-fitted over the electrode pins protruding from the top of the cylinder. Remove cylinder plugs from cylinder by pulling vertically.
- Using slot screwdriver, loosen the steam hose clamp(s) and pull steam hose off the cylinder vertically.
- Using a small slotted screwdriver, depress tab on the re-usable tie wrap, if present, around the middle of the cylinder. This will loosen the tie wrap to come apart for re-use later on.
- Cylinder is now ready to be lifted out of the unit. CAUTION: Cylinder and any undrained water might still be HOT.

## MANDATORY CLEANING OF THE DRAIN VALVE

Always clean the drain valve before installing a new cylinder since the valve port may be as dirty as the used cylinder.

- Remove used cylinder as previously described. NORTEC does not recommend the use of any acid solutions to clean the used cylinder. Always replace a used cylinder.

**Figure #15**

### Reassembly of the Drain Valve and Fill Valve

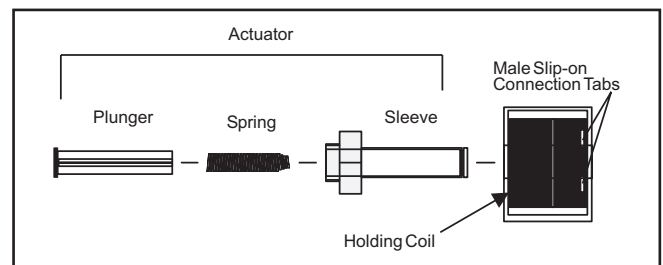

- Note that ring terminal for drain valve green ground wire is sandwiched between drain valve body and drain pan.
- Remove two screws securing drain valve body to drain pan. Disconnect the two slip-on terminals from the two tabs on the (24VAC) drain valve coil.
- Remove hose clip and hose connection from drain valve body.
- Drain valve assembly is now free to be taken to a sink for disassembly and cleaning.

6. Remove snap-fit red cap from coil assembly and slide coil off the actuator.
7. Loosen actuator with wrench and unscrew from plastic valve body.
8. Clean the exposed core and spring and plastic drain valve port.
9. Important: Tapered end of spring must be installed toward the solenoid. Reassemble, tighten actuator 1/4-turn past hand-tight.
10. Clean out the end of the hose, then reconnect it to the drain valve body with the clamp.
11. Fit mounting screws through drain valve body, one through ring terminal on green ground wire.
12. WARNING: To prevent the possibility of electrical shock the green ground wire must be reinstalled before power is restored.
13. Push the two slip-on terminals back onto the two tabs on the coil. The terminals, although not identical, are reversible.

## HOW TO INSTALL THE REPLACEMENT CYLINDER

1. Reverse procedure should be followed to install new cylinder. Main disconnect is to be left open until cylinder is completely installed and reconnected.
2. Ensure that cylinder is secured properly by the re-usable tie wrap and mounting brackets within the unit.
3. The cylinder plug wires are color-coded in accordance with colored dots beside the electrode pins on top of the cylinder.
4. This color-coding must be adhered to when replacing cylinder plugs on pins.
5. With cylinders having six primary voltage cylinder plugs, it should be noted that there are two of each color.
6. Care must be taken so that cylinder leads of the same color are always directly opposite each other as indicated by the dot formation on the top of the cylinder.
7. The white cylinder plug on all units is for the sensor electrode which always goes on the single pin surrounded by a plastic shoulder.
8. Ensure that cylinder plugs fit snugly on the pins.
9. If cylinder plugs become loose, it is best to obtain a new replacement plug. Consult factory.

**Figure #16**  
**Cylinder Plug Installation**

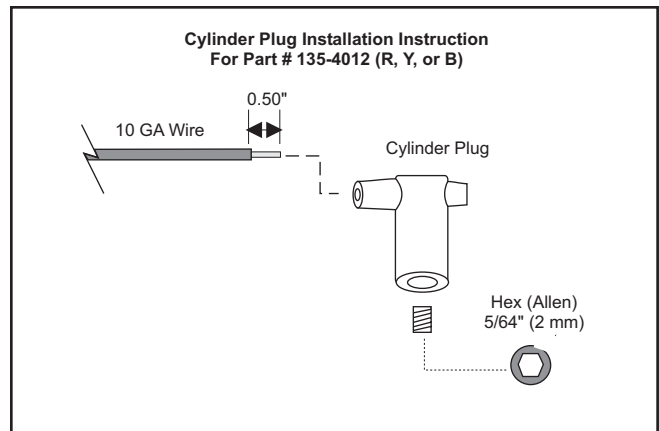

## EXTENDED SHUTDOWN

Before disconnecting power to the humidifier for a period of extended shutdown, **ALWAYS DRAIN** the cylinder first. Otherwise, the electrodes are subject to harmful corrosion which drastically shortens cylinder life. Do NOT leave the switch in the DRAIN position indefinitely as the drain coil could burn out. Leave the switch in the OFF position and “open” the main external fused disconnect to stop power to the humidifier. Close the shut off valve in the water supply line feeding the humidifier. Lock the cabinet door(s) to prevent unauthorized tampering. All doors are factory supplied with keyed locks. **DO NOT LEAVE KEY IN LOCK. ACCESS SHOULD BE LIMITED TO AUTHORIZED PERSONNEL ONLY.**

As long as the NHMC is powered, it will automatically drain the cylinder when there has not been a call for humidity for an extended period of time. The cylinder will remain empty until there is a call for humidity at which time the fill valve will open and refill the cylinder. The unit will go through its normal stabilization process for optimum operation.

**Figure #17**  
**Where To Oil**

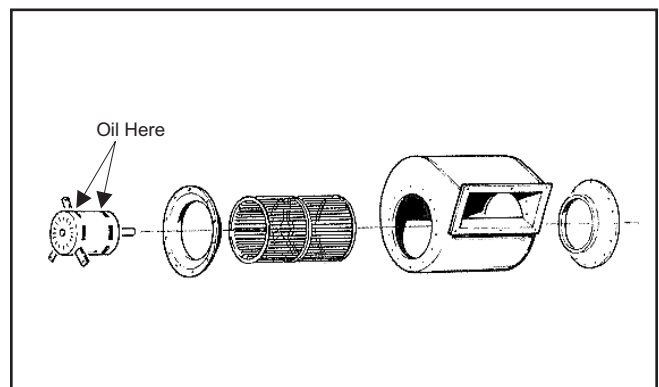

This feature will reduce the possibility of corrosion of the electrodes and the possible accumulation of algae and bacteria growing in the cylinder.

## BUILT ON AND REMOTE MOUNTED BLOWER PACKS (BOBP's / RMBP's)

FAN MOTOR OILING: The blower pack fan motor requires occasional oiling of motor bearings. To do this, open up the blower pack top and oil the motor with ten drops of SAE-20 grade motor oil. Refer to Figure #6 for oiling slots. It is important to oil the fan motor every four months to preserve long life and to maintain the fan's warranty. It is not necessary to disassemble the fan/motor assembly. The exploded view is for visual purposes only.

## TROUBLESHOOTING

PLEASE READ THIS SECTION BEFORE REFERENCING SPECIFIC DIAGNOSTIC MESSAGES.

1. Ensure the installation detail conforms with the recommendations contained in the Installation Manual, Form #XX-161.
2. Understanding the Principle of Operation is an asset when troubleshooting. This information is readily available from your local representative.
3. When contacting your local representative or NORTEC, for troubleshooting assistance, please ensure the serial number has been obtained for reference purposes.
4. Whenever the troubleshooting steps indicate a problem with the main pc-board, first check all connections at the main pcb (including the ribbon cable connections at the center of the main pcb) before ordering replacements.

### STARTING POINT

If nothing is working, check for 24 VAC output from the stepdown transformer (see wiring diagram). If there is no 24 VAC output, the transformer might have been damaged if external controls were installed and/or connected with the field-supplied fused disconnect on. If this is the case, the transformer must be replaced.

The conductivity of the water within the cylinder must be controlled, in order for the humidifier to function properly. The fill and drain rates must be maintained. Filling too quickly can cause over-amping and automatic shutdown or blown fuses. Filling too slowly can cause insufficient steam output and humidity levels. Water supply pressure should be between 30 and 80 psig, ideally 55 to 60 psig. Draining too slowly can cause over-concentration and

malfunction due to foaming. These are just some examples of what can go wrong if the fill and drain rates are not maintained.

Fill rates of suspect units should be checked. Open the disconnect to cut off all power in the humidifier before reaching inside. One of the 24VAC wires to each primary voltage contactor holding coil (some models have two contactors per cylinder) should be temporarily disconnected for this test. This way, no boiling occurs during the test so as not to detract from the fill rate. Fill rates should measure nominally at 1" to 1-1/2" of vertical rise in water level in the cylinder in one minute.

If filling too quickly, check for excessively high supply water pressure (over 80 psig). If water pressure is correct, verify fill valve body orifice (consult factory). If filling too slowly, look to probable causes described under Error 3 later in this manual. Check rate with steam line disconnected.

Manual drain rates of suspect units should be checked using Figure #18 as reference times.

**Figure #18**  
**Manual Drain Times**

CYL. SIZE (SERIES)	PROPER TIME (sec) TO DRAIN MANUALLY FROM SEAM TO EMPTY
	BEIGE BODY DRAIN VALVE
500/600	2 minutes and 52 seconds ± 10 sec.
400	1 minute and 20 seconds ± 5 sec.
300	43 seconds ± 2 sec.
200	25 seconds ± 1 sec.

If time measurements are longer, repeat with external drain disconnected (and draining into a pail) to know if external drain is impeding flow.

Clogged strainer and/or clogged drain valve will cause shortened cylinder life. But start by determining what caused the strainer and/or drain valve to clog in the first place.

Do not assume that if strainer and/or drain valve are clogged that they are to blame. If the external drain has been impeding flow, then waste accumulates, resulting in a clogged strainer and/or clogged drain which, in turn, results in shortened cylinder life.

Clean the drain valve; start with a fresh cylinder. Then measure the manual drain time with and without the external drain connected. Is the external drain impeding flow? NORTEC recommends an open external drain line. See Form #XX-161.

## **NHMC/NHP**

The self-diagnostic system built into the NHMC is continually checking the status of the electrical circuits to the fill valve, drain valve, primary voltage contactor, high water sensor and steam cylinder. The modulating signals from external humidistats and reduced manual capacity settings are taken into consideration. When problem symptoms are found, the NHMC/NHP will take self-corrective actions, if applicable. It will, if necessary, respond by shutting itself down.

The NHMC/NHP communicates its findings to the user by way of the unit's status lamps and signals sent to the terminal strip for optional external remote indication. **Even more directly, the NHMC has an alphanumeric system message to the user via the LCD (liquid crystal display).**

All of this is summarized for each system message in the following easy-to-follow format.

## **NHMC/NHP Explanation of System Messages and Responses — EPROM : 2.XXN**

### **1. Maximal Level (Shown on NHMC LCD display only)**

Symptom(s) Diagnosed: Water has reached the top of the cylinder and activated the high water sensor circuit. This is not an error or fault diagnostic. Note: This is normal on start-up and at end of cylinder life before Error 4 shows.

Probable Cause(s): Normal on startup with a new cylinder or a cylinder that has been completely drained because of an extensive off period. Can last for several hours until the water in the cylinder has concentrated or the electrodes can no longer provide rated capacity (or adjusted capacity). Water level automatically rises to seek out fresh electrode surface to meet the demand.

Unit Takes Self-Corrective Action: Yes. It stops the fill valve to prevent overfilling.

### **2. Excess Current - Error 1**

Symptom(s) Diagnosed: Current drawn on monitored primary lead to cylinder has reached or exceeded 125% of its rated amps. The unit will have tried to self-correct prior to system shutdown by draining water from the cylinder or

de-energizing the contactor momentarily while it drains.

#### Probable Cause(s):

1. Cylinder water is over-concentrated (too conductive) due to restricted drain, short-cycling by controls, supply water not within acceptable limits (too conductive), improper fill rate, incorrect cylinder being used.
2. Water level too high due to leaking fill valve, excess condensate return from steam line.

#### Corrective Action:

1. Note water level.
2. Manually drain cylinder while checking drain rate (refer to Figure #7 for proper drain times). If too slow correct cause.
3. Turn unit back on and check the fill rate (1 - 1-1/2 inches per minute)
4. Once RH% set point is attained, monitor cycle time.

Response: See Figure #2, NHMC/NHP System Messages

### **3. No Current - Error 2**

Symptom(s) Diagnosed: Full cylinder (MAXIMAL LEVEL) detected with no current draw sensed by the electronics on monitored primary lead to cylinder.

#### Probable Cause(s):

1. No current being drawn, specifically on the monitored primary lead to the cylinder, or the actual current not being sensed.
2. False detection of a full cylinder (water level within inches of cylinder top) due to foaming, wiring/connection problem, circuit board failure.

Corrective Action: Check water level in cylinder.

1. If full (within 4" of top) disconnect white sensor plug on cylinder, reset unit and check monitored primary lead to cylinder for current with amp clamp. If current present, determine why main PCB does not sense the current. If no current, present determine cause of primary voltage interruption.
2. If not full disconnect white sensor plug on cylinder, reset unit. If error 2 does not reoccur within two minutes, cylinder was likely foaming and should be flushed. If error 2 does reoccur within two minutes, there is a problem with the high water sensor PCB. If error 2 occurs with the high water sensor PCB disconnected, there is a problem with the main PCB.

Response: See Figure #2, NHMC/NHP System Messages

#### 4. Max. Filling Time - Error 3

Symptom(s) Diagnosed: Time dependent. Neither Maximal Level (full cylinder) is detected, nor is there enough current drawn to meet capacity demand. Current monitored on primary lead to cylinder is greater than zero and not decreasing. The unit will have tried to self-correct prior to system shutdown by pulse activating the drain valve to possibly clear any debris holding the drain valve open.

Probable Cause(s):

1. Steam line restriction causing back pressure.
2. Improper fill rate.
3. Leaking drain valve
4. Full cylinder not detected.

Unit Takes Self-Corrective Action: Yes. It pulse-activates the drain valve to possibly clear any dirt. It retests. If the symptoms persist after two attempts, it then responds as shown in Figure #2.

Corrective Action:

1. Check for water leaking from drain. If present, correct the drain valve deficiency (check for debris holding drain coil plunges open).
2. Ensure the steam line, from the cylinder outlet to the steam distributor (duct or blower pack), is properly installed, to ensure back pressure is not the case.
3. Check water level in cylinder.
4. If full reset unit and ensure there is a demand for steam (the green LED on unit door will stay illuminated. Maximal Level should be indicated on the LCD display and both green and yellow LED is on the unit door illuminate almost immediately. If Maximal Level is not indicated, a problem exists with the high water sensor circuitry.
  - a) Check wiring of the high water sensor PCB (refer to unit wiring diagram).
  - b) Check for amperage on all wires at the cylinder, with an amp probe (amp clamp). If amperage is not detected on all wires, correct primary wiring deficiency. If amperage is detected on all wires, proceed to next step.
  - c) Place a jumper across 42 and 48 of main PCB for five seconds. If Maximal Level is not

displayed and the fill valve does not energize (green LED must be illuminated), the main PCB is defective. If Maximal level is displayed, a problem exists with the cylinder or the high water sensor PCB. A voltage of 85 VAC or greater across the orange wires of the high water PCB ( one orange wire terminates at the white sensor plug attached to the soldered pin of the cylinder, the other terminates at one of the contactor connections) will signal a full cylinder (Maximal Level) to the main pcb. If this voltage does exist, the problem is with the high water PCB, if not, the problem is within the cylinder (can be caused by cylinder being past end of life.

5. If not full, drain cylinder, reset unit, and check the fill rate (refer to Figure #2 ). If the fill rate is correct, back pressure is the likely cause and should be rechecked.

Response: See Figure #2, NHMC/NHP System Messages.

#### 5. Cylinder Spent - Error 4

Symptom(s) Diagnosed: Water level stays high, cycling on and off Maximal Level (full cylinder), without an increase in output/amp draw or reaching demand.

Probable Cause(s):

1. Cylinder has reached end of life due to insulative mineral coating on electrodes.
2. New cylinder start up with low incoming water conductivity.

Corrective Action:

1. If the cylinder is not new, replace the cylinder immediately. Within approximately three days, the unit will shut itself down on Error 9 resulting in no output instead of reduced output.
2. If the cylinder is new, the electronics will differentiate cylinder spent from new cylinder start up and the displayed error will discontinue without a shutdown on Error 9.

Response: See Figure #2, NHMC/NHP System Messages.

#### 6. No Current - Error 5

Symptom(s) Diagnosed: Time dependent. No current sensed by the electronics on the monitored primary lead to the cylinder. The unit will have tried to self correct prior to system shutdown by pulse activating the drain valve, to possibly clear any debris holding the drain valve open.

Probable Cause(s):

1. No current being drawn on the monitored primary lead to the cylinder, or the actual current is not being sensed.
2. Water does not reach the electronics due to a restricted water supply line or due to a constantly open/leaking drain valve preventing a water level increase.
3. High duct static pressure blowing back into the fill cup (via steam line, empty cylinder) diverting the fill cup water to the overflow.

Unit Takes Self-Corrective Action: Yes. It pulse-activates the drain valve to possibly clear any dirt holding the seal open. It re-tests. If symptoms persist after two attempts, it then responds as shown in Figure #2.

Corrective Action:

1. Check the water level in the cylinder.
2. If there is water in the cylinder (1/5 of a full cylinder or more) check monitored primary lead to the cylinder for current with an amp clamp.
  - a) If current is present with zero output indicated on the display, the problem is with the main PCB.
  - b) If no current is present determine the cause of the primary voltage interruption.
3. If there is little or not water in the cylinder turn the unit off and disconnect the steam line at the cylinder. Reset the unit and monitor filling.
  - a) If unit fills and Error 5 does not reoccur, the problem was likely caused by air flow through the fill system and can be permanently corrected by installing a U trap on the fill line between the fill cup and the drain valve body.
  - b) If unit does not fill, then turn the unit off and clean and check the drain valve (refer to section on Mandatory Cleaning of the Drain Valve in this manual) to ensure that there are no obstructions or leaks in the drain valve preventing it from holding water in the cylinder, and check water inlet for obstructions.
4. Turn unit back on and see if it will fill.
  - a) If unit still does not fill, then with the unit turned on, check for 24 VAC across the fill valve (there must be a call for humidity).
  - b) If 24 VAC is present, then the problem is with the fill valve.

- c) If 24 VAC is not present, then check for 24 VAC across 6 and 14 on the PCB.
- d) If 24 VAC is not present across 6 and 14 of the PCB, then the problem is with the main PCB.
- e) If 24 VAC is present across 6 and 14 of the PCB, then check for a break in the circuit to the fill valve.

Response: See Figure #2, NHMC/NHP System Messages.

### 7. Output Too Low - Error 6

Symptom(s) Diagnosed: Time dependent. Neither Maximal Level (full cylinder) is detected, nor is there enough current drawn to meet capacity demand. Current monitored on primary lead to cylinder greater than zero but decreasing.

Unit Takes Self-Corrective Action: Yes. It pulse-activates the drain valve to possibly clear any dirt holding the seal open. It re-tests. If symptoms persist after two attempts, it then responds as shown in Figure #2.

Probable Cause(s): Refer to Error 3.

Corrective Action: Refer to Error 3.

Response: See Figure #2, NHMC/NHP System Messages.

### 8. Electronic - Error 7 (NHMC only)

Symptom(s) Diagnosed: The electronics of the main PCB have diagnosed the main PCB as defective.

Probable Cause(s):

1. A spike in the primary power supply to the humidifier, either high (surge) or low (brown out), causing the electronics to experience a logic glitch.
2. A problem with the main PCB.

Corrective Action:

1. Reset humidifier and monitor display. If Error 7 reoccurs within one minute of resetting the unit, the problem is with the main PCB. If Error 7 is not repeated, the primary power to the unit is suspect.

Response: See Figure #2, NHMC System Messages.

## 9. Phase Interrupt - Error 8 (NHMC only)

Symptom(s) Diagnosed: The 24 VAC to the main PCB, across terminals 44 and 46 is interrupted.

Probable Cause(s):

- a) A wiring problem leading to an interruption of the 24 VAC to terminals 44 and 46 of the main PCB.
- b) A problem with the main PCB.

Corrective Action:

1. With the unit switched on, measure across terminals 44 and 46 of the main PCB for 24 VAC. If not present, find the cause of interruption. If present, the problem is with the main PCB.

Response: See Figure #2, NHMC System Messages

## 10. Cyl. Lifespan End - Error 9

Symptom(s) Diagnosed: The criteria for diagnosing Cylinder Spent - Error 4 has expired and cylinder has not been replaced. Humidifier has shut down to avoid unsafe operation.

Probable Cause(s): Refer to Error 4.

Corrective Action: Refer to Error 4.

Response: See Figure #2, NHMC/NHP System Messages.

## Troubleshooting Dual Cylinder Units

Double units, NHMC-150 and 200, are two circuits in one cabinet sharing one LCD display. A ribbon cable between the RS232 ports links the two circuits. The left circuit is the master. [1] on the display means left side. [2] on the display means right side.

Refer to double unit operation on in the NHMC Installation and Operation Manual.

When a fault occurs on the right side of a double unit, both sets of lamps (and remote relays) will come on indicating that a fault has occurred. The left side (master) will display its own faults as well.

The LCD will indicate which fault has occurred and on which side of the unit, [1] or [2]. The side not faulted will continue to operate as usual.

The side which has shut down on fault can be treated as a single circuit using the same troubleshooting guidelines as previously described.

## NHB

The NHB checks the status of the electrical circuits to the fill valve, drain valve, primary voltage contactor, high water sensor and steam cylinder. The manual capacity setting, if reduced, is taken into consideration. When problem symptoms are found, the NHB will, if necessary, respond by shutting itself down.

The NHB communicates its findings to the user by way of the unit's status lamps and a 24 Vac (maximum 100 mA maximum) signal sent to the terminal strip for optional external remote indication.

The signal for remote indication comes in response to the following symptoms. In each case, the NHB shuts itself down. The green status lamp goes off, but the yellow status lamp (and remote fault relay) remain on.

### NHB Explanation of Automatic Shutdowns

#### 1. Excess Current

Symptom(s) Diagnosed: Current in steam cylinder increases beyond the fill off and emergency drain on triggers. Current reaches 150% of FLA (i.e. 134% of fill off rated amps; i.e. 134% of amps on spec. label) for 1 second.

Probable Cause(s): Blocked drain due to blocked cylinder strainer or blocked drain valve or blocked external drain line. No power to drain valve at emergency drain on trigger. Power remains on fill valve at fill off trigger. Wrong steam cylinder (too conductive). Wrong fill valve (orifice too big). Wrong supply voltage (too high). Supply water too conductive. Contained water too conductive. 100% softened supply water is often too conductive. Measure conductivity and report findings to factory if suspected. Mineral bridge between electrodes.

Unit Takes Self-Corrective Action: It has already tried to control current with fill off and emergency drain on triggers. It then responds as shown below.

Response:

UNIT CONTACTOR	UNIT STATUS LAMPS		REMOTE INDICATION (24 Vac to:)
	YELLOW	GREEN	61-20 "YELLOW"
OFF	ON	OFF	ON

## 2. Max. Filling Time

Symptom(s) Diagnosed: The fill valve has been “on” for a longer time than is normally required for non-zero current to flow between the electrodes or for water level in the cylinder to reach the high water sensor pin.

Probable Cause(s): Blocked drain due to blocked cylinder strainer or blocked drain valve preventing water from entering the cylinder. Drain valve leaking due to dirt in seal or powered by defective main PC board or powered by wiring error. High water sensor circuit not responding due to sensor plug not connected or defective high water sensor PC board or wiring error or defective main PC board. Water supply rate too low or zero due to too low pressure or line restriction or clogged built-in strainer. Too low supply water conductivity. DI (de-ionized) or RO (reverse osmosis) supply water has almost no conductivity. Measure conductivity and report findings to factory if suspected.

Response:

UNIT CONTACTOR	UNIT STATUS LAMPS		REMOTE INDICATION (24 Vac to:)
	YELLOW	GREEN	61-20 “YELLOW”
OFF	ON	OFF	ON

## NHB Explanation of Symptoms Without Automatic Shutdown

### 4. No Current But High Water Sensor On

Symptom(s) Diagnosed: High water level in the steam cylinder is detected, yet no current is detected in the steam cylinder.

Probable Cause(s): Sensor plug connected to wrong cylinder pin. High water sensor PC board defective (activates with no water). Main PC board defective (activates high water circuit without sensor PC board). Monitored leg of three phase power supply is dead. Main PC board defective (does not sense current when current is present in monitored leg).

### 5. Cylinder Spent

Symptom(s) Diagnosed: The high water sensor circuit is activated. Other criteria are used to distinguish cylinder spent from normal startup and diagnose the steam cylinder as spent, as previously described.

Probable Cause(s): As pure steam is produced from tap water, most minerals are drained by the auto-adaptive control system. However, it is inevitable that minerals will buildup on the electrodes and strainer inside the steam cylinder. It is unavoidable and the cylinder is intended to be disposable.

Unit Takes Self-Corrective Action: The humidifier continues to operate with gradually decreasing capacity, giving the user notice by responding as shown below.

Response :

UNIT CONTACTOR	UNIT STATUS LAMPS		REMOTE INDICATION (24 Vac to:)
	YELLOW	GREEN	61-20 “YELLOW”
ON	ON	ON	ON

### 6. No Current But Humidistat Calling

Symptom(s) Diagnosed: For a few minutes, no current is detected in the steam cylinder, despite a demand for humidity. (Current is not expected to be zero when there is a demand for humidity.)

Probable Cause(s): Drain valve is leaking, so water never reaches the electrodes. Water supply is obstructed. Contactor is not activated. Supply water is “pure” without conductivity. Fill valve is blocked. Fill valve is not being activated. Supply water pressure is too low (less than 30 psig). Wrong orifice in fill valve. High duct static pressure blows back into the fill cup (via the steam line and empty cylinder) diverting the fill water to overflow. (Taking the steam hose off until some water gets into the cylinder solves this.)

### 6. Output Too Low

Symptom(s) Diagnosed: For a few minutes, current does not increase in the steam cylinder, despite the fill valve being activated. (Current is expected to increase soon after the fill valve is activated.)

Probable Cause(s): Drain valve is partially open, so fill rate maintains non-zero but non-increasing current. Continual overflow because high water sensor circuit did not respond to full cylinder. Supply water insufficiently conductive. Fill valve is partially restricted due to dirt, pinched supply line, or wrong orifice. Steam supply line is obstructed so back pressure causes continual overflow.

Supply water pressure is too low (less than 30 psig).

## 7. Electronics

Symptom(s) Diagnosed: When on/off/drain switch is switched on, green status lamp does not come on.

Probable Cause(s): Green status lamp is damaged. (Long life LED should never burn out.) NHB electronic board assembly was damaged in shipment or installation. Electronics need to be replaced.

## 8. Yellow and Green Status Lamps Both On

Symptom(s) Diagnosed: Water has reached the top of the cylinder and activated the high water sensor circuit. Note: This is normal on startup and at end of cylinder life.

Probable Cause(s): Normal on startup with a new cylinder. Can last for several hours until cylinder reaches optimum contained water conductivity or electrodes can no longer provide rated capacity (or adjusted capacity). Water level automatically rises to seek out fresh electrode surface to meet the demand.

Unit Takes Self-Corrective Action: Yes. It stops the fill valve to prevent overfilling.

## USING THE WIRING DIAGRAM

Fixed to the inside of each unit's door is a wiring diagram showing all of the internal (and most of the external) wiring details. Additional external wiring details can also be found with any electrical accessories purchased from NORTEC.

The following is a detailed explanation of how the NH humidifier (with and without options) operates. Direct reference is made to the wiring diagram. Reviewing the proper function in detail will make it easier to troubleshoot if something goes wrong.

The wiring diagram details a 24 Vac control circuit and a primary voltage circuit.

### NHMC/NHP

A primary-to-24 Vac 75 VA transformer, tapped from the primary, powers the 24 Vac control circuit. One leg of the secondary is connected to ground and terminals 6 and 46 on the electronics. The "hot leg" finds its way to the electronics via the following in series: the external on/off controls (if present), terminals 8-10, the blower pack mounted on/off

humidistat (if present), terminals 84-85 and finally the cabinet mounted on/off humidistat (if present). 24 Vac arrives at the electronics' terminals 10 (hot) and 6 (ground). A second "hot leg" takes a more direct route to terminals 8, 18, 34, 38, 44 on the electronics via the "on switch" and the door interlock switch in series.

The primary voltage circuit is what turns the water in the cylinder to steam for humidification. The internal primary fuses (if present) are followed by the primary contactor(s). When the 24 Vac coil is powered, the contactor "makes". One primary leg is routed through the core of the linear Hall Effect current sensing circuit on the electronics, then it goes to the cylinder. The high water sensor board has a primary voltage side. One leg connects to the primary leg; one leg connects to the short sensor pin in the top of the cylinder. A potential, somewhat less than primary, is picked up by the sensor at high water level, which "makes" the red/black circuit on the low voltage side. This creates a resistive loop across terminals 42-48 on the electronics which stops the fill valve until water boils down below the sensor pin.

Back at the electronics, the contactor receives its "hot leg" from terminal 12. The fill receives its "hot leg" from terminal 14. The drain receives its "hot leg" from terminal 16. Unlike the contactor and fill, the drain gets its "ground leg" directly from the transformer. It does not depend on the air proving switch to activate.

The yellow and green unit status lamps are LED's. Polarity is important. Terminal 4 is positive dc supply. Terminals 22 and 24 are switched dc grounds for yellow and green respectively.

### NHB

A primary-to-24 Vac 75 VA transformer, tapped from the primary, powers the 24 Vac control circuit. One leg of the secondary is connected to ground and terminal 6 on the electronics. The "hot leg" finds its way to the electronics via the following in series: the external on/off controls (if present), terminals 8-10, the blower pack mounted on/off humidistat (if present), terminals 84-85 and finally the cabinet mounted on/off humidistat (if present). 24 Vac arrives at the electronics' terminals 10 (hot) and 6 (ground). An onboard 3.15 amp glass fuse protects the circuit. A second "hot leg" takes a more direct route to terminals 8 and 18 on the electronics via the "on switch" and the door interlock switch in series.

The primary voltage circuit is what turns the water in the cylinder to steam for humidification. The internal primary fuses (if present) are followed by the primary contactor(s). When the 24 Vac coil is powered, the contactor "makes". One primary leg is routed through the core of the linear Hall Effect current sensing circuit on the electronics, then it goes to the cylinder. The

high water sensor board has a primary voltage side. One leg connects to the primary leg; one leg connects to the short sensor pin in the top of the cylinder. A potential, somewhat less than primary, is picked up by the sensor at high water level, which “makes” the red/black circuit on the low voltage side. This creates a resistive loop across terminals 2-4 on the electronics which stops the fill valve until water boils down below the sensor pin.

Back at the electronics, the contactor receives its “hot leg” from terminal 12. The fill receives its “hot leg” from terminal 14. The drain receives its “hot leg” from terminal 16. Unlike the contactor and fill, the drain gets its “ground leg” directly from the transformer. It does not depend on the air proving switch to activate.

The yellow and green status lamps are LED's. Polarity is important. Terminal 26 is positive dc supply. Terminal 22 and 24 are switched dc grounds for yellow and green respectively.

### **BLOWER PACKS**

An optional blower pack (BP), if present, gets its primary voltage from inside the humidifier. This way, only one external power source has to be connected to the equipment.

## **TERMS USED**

**RATED AMPS:** Refers to amps listed on the humidifier specification label.

**SHORT CYCLING:** When the 'on time' of the humidifier is less than ten minutes upon a call for humidity. To correct short cycling, all humidifiers have a capacity adjustment which allows the output of the humidifier to be reduced as low as 20% of rated output, thus extending the 'on time' required to maintain output.

**FOAMING:** The phenomenon which can occur in water when the impurities, already in the water, reach an excess concentration as result of boiling away pure water and the continued boiling action agitating the contained water. The humidifier electronics are designed to prevent this occurrence although in extreme cases water will foam with little concentration, making it necessary to have the drain time of the water, contained in the cylinder, increased. Foaming is normally caused by short cycling, a restricted drain, or back pressure. The foam, generated in these instances, is conductive and may lead to a false full cylinder indication if the level of the foam approaches the top of the cylinder.

**BACK PRESSURE:** Restriction of steam flow caused by long steam runs, improperly sloped steam lines, elbows changing the direction of the steam flow from horizontal to vertical without a drain leg, any plumbing detail allowing the accumulation of condensate, undersized steam line, improper steam distributor, downward air flow onto the distributor creating excess static pressure at the steam outlets or high static pressure ducts (not probable). To overcome excess static pressure in the duct, a fill cup extension kit should be used. In downflow applications, a downflow distributor should be used but in some cases the fill cup extension will also be required.

**RESET UNIT (HUMIDIFIER):** To reset the humidifier, the on/off/drain switch at the front of the humidifier should be switched to the off position for a minimum of five seconds and then switched back to the on position.

**MONITORED LEG:** Refers to the primary wire, to the cylinder, which loops through the current sensing device on the main pcb. This wire is terminated at the red cylinder plug at the cylinder. Units with six primary wires to the cylinder will monitor only one of the two wires, terminating with red plugs.



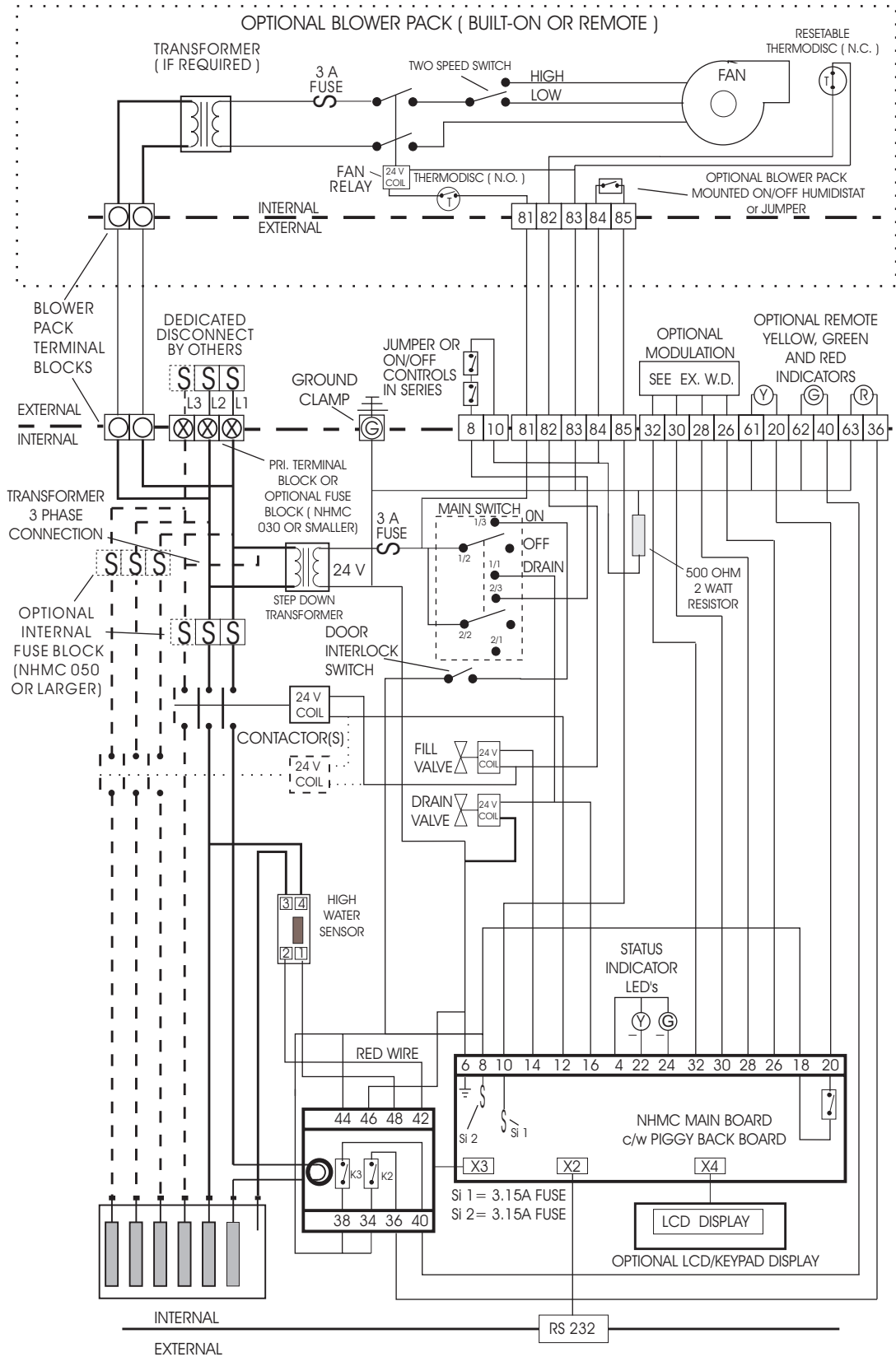

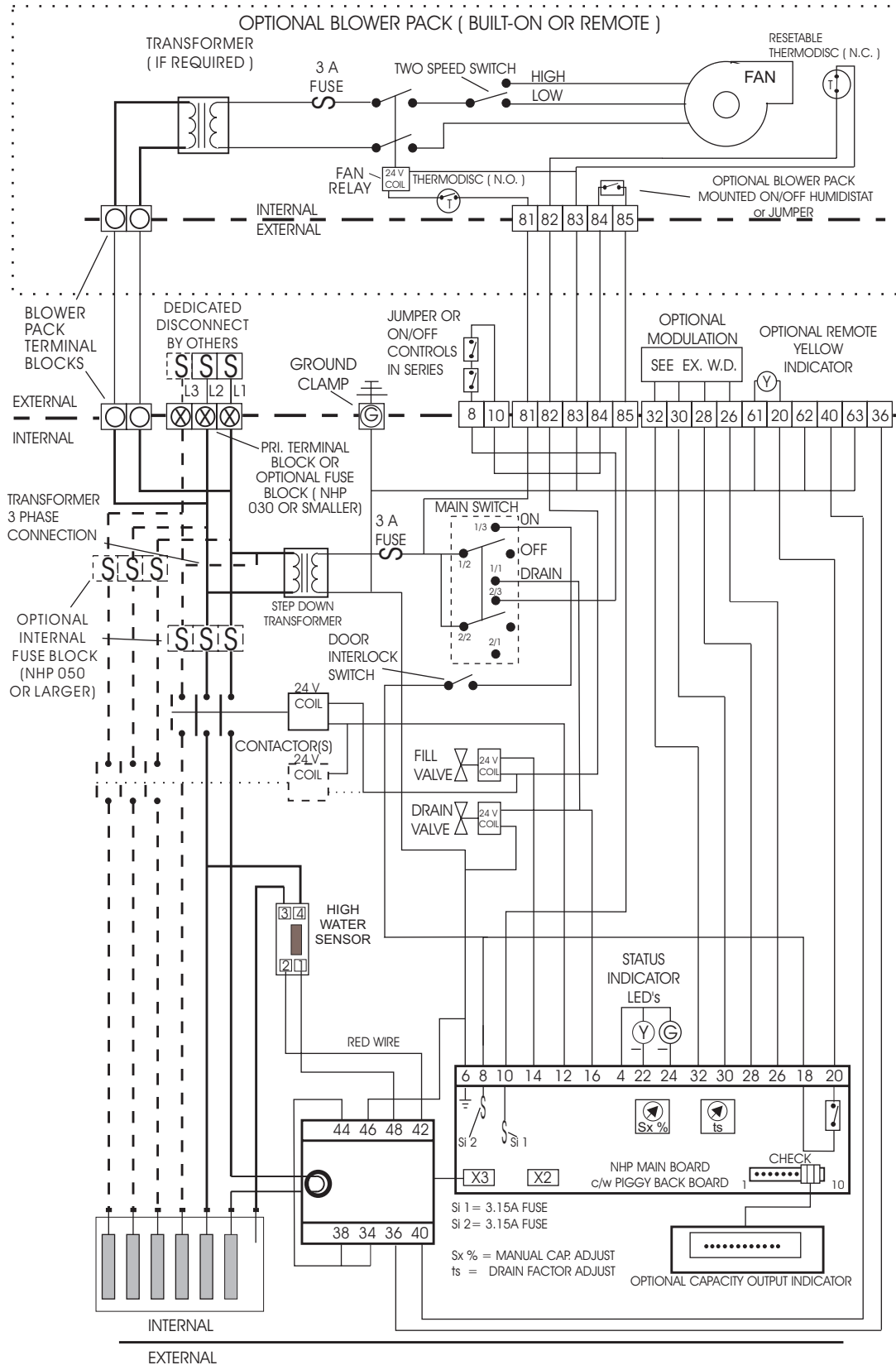

## Humidifier Mandatory Pre Start-up Checklist (p. 1 of 1)

Unit Serial #: \_\_\_\_\_ # of humidifiers: \_\_\_\_\_ Tag: \_\_\_\_\_  
 Unit type: \_\_\_\_\_ Voltage: \_\_\_\_\_ V/ \_\_\_\_\_ ph Steam output: \_\_\_\_\_ lbs/hr  
 Customer/Job: \_\_\_\_\_ Address: \_\_\_\_\_  
 Inspected by: \_\_\_\_\_ Date of inspection: \_\_\_\_/\_\_\_\_/\_\_\_\_

### WATER QUALITY:

Well water  City water  Softened water  RO / DI water   
 Conductivity: \_\_\_\_\_ mhmos Hardness: \_\_\_\_\_ gr.

### HUMIDIFIER MOUNTING:

Clearances around the unit	Acceptable	Obstruction
- Front (door opens freely?)	3ft min	_____
- Top (steam lines)	2ft min	_____
- Bottom (fill, drain, controls)	2ft min	_____
- Right (main pwr)	2ft min	_____

### STEAM LINES:

- Slope up 2" per 12"   
 - Slope down 1/2" per 12"   
 - Traps   
 - Insulated   
 - Length/Size \_\_\_\_\_ / \_\_\_\_\_  
 - 90 deg. elbows  qty: \_\_\_\_\_  
 - Can condensate be trapped anywhere in the steam line? Yes  no

### CONDENSATE LINES:

- Sloped back to drain   
 - Trapped 2" more than static duct pressure   
 - Size \_\_\_\_\_  
 - Stainless steel  or plastic   
 - \_\_\_\_\_% Vertical \_\_\_\_\_% Horizontal  
 - 45 deg. Elbows  qty: \_\_\_\_\_

### WATER LINES:

- 1/2" at max 4ft from the unit  - 3/8" connection at fill   
 - water pressure: 30-80psig  - PVC  - Stainless steel

### DRAIN LINES:

- Air gap located within 3ft of the unit  - Sloped to drain  - Size: \_\_\_\_\_

### CYLINDER:

- Cylinder properly installed and sitting upright

### WIRING:

- No loose wires around the unit or on the PC board? yes  no

### CONTROLS:

Installed	Location / Wiring /Setting	Installed	Location / Wiring /Setting
- High limit:	<input type="checkbox"/> _____	- Air proving:	<input type="checkbox"/> _____
- Mod controller:	<input type="checkbox"/> _____	- Other:	<input type="checkbox"/> _____

### POWER:

- Voltage, amperage rating and fuse correspond to Spec Label   
 - Disconnect switch located close to humidifier



# NH Electric Steam Humidifier

## Humidifier Mandatory Start-up Checklist & Quick Reference (p. 1 of 1)

Unit Serial #: \_\_\_\_\_ # of humidifiers: \_\_\_\_\_ Tag: \_\_\_\_\_

Unit type: \_\_\_\_\_ Voltage: \_\_\_\_\_V/\_\_\_\_ph Steam output: \_\_\_\_\_lbs./hr

Customer/Job: \_\_\_\_\_ Address: \_\_\_\_\_

Start-up by: \_\_\_\_\_ Date of start-up: \_\_\_\_/\_\_\_\_/\_\_\_\_

---

### 1. PRELIMINARY:

- Pre-start-up checklist completed? yes  no

If no, return to **Pre-Start-up Checklist** before going on with start-up procedure.

### 2. START-UP PROCEDURE:

The prerequisites for getting power and water into the steam cylinder are as follows:

- check that main breaker is on and power is at the unit.
- check that main water shut-off valve is open.
- on/off/drain switch must be switched on.
- control circuit 8-10 must be made.
- modulation humidistat, if present, must be calling.
- control circuit 82-83 must be made.
- control circuit 84-85 must be made.
- cabinet mounted humidistat, if present, must be calling.
- door interlock switch must be made (interlock switch can be pulled out to operate unit).

The unit will undergo a self-test (P and MC models only) to ensure integrity of all the components:

- Lamp green (observe light energize)
- Lamp yellow (observe light energize)
- Contact relay 1 (24V to 61-20 for rem. yellow)
- Drain (sound and 24 volt at solenoid)
- Fill (24 volt at fill solenoid)
- Contactor (listen to contact pulling in) (Unit must be calling).
- Contact relay 2 (24V to 63-36 for rem. red)
- Contact relay 3 (24V to 61-20 for rem. green)
- Internal test (Test completed)
- Green and yellow blink together to show test passed

It will then start filling the cylinder and begins normal operation. Most water does not contain enough conductivity for full boil on initial start-up. Units will need to concentrate the water over a time period (hours to days). During this process both lights are on.

### Remarks:

---



---



# NH Electric Steam Humidifier

## Periodic Maintenance Checklist & Quick Reference (p. 1 of 2)

Unit Serial #: \_\_\_\_\_ # of humidifiers: \_\_\_\_\_ Tag: \_\_\_\_\_

Unit type: \_\_\_\_\_ Voltage: \_\_\_\_\_V/\_\_\_\_ph Steam output: \_\_\_\_\_lbs./hr

Customer/Job: \_\_\_\_\_ Address: \_\_\_\_\_

Maintenance by: \_\_\_\_\_ Date of maintenance: \_\_\_\_/\_\_\_\_/\_\_\_\_

### WHEN TO REPLACE THE CYLINDER:

#### NHMC light indication and LCD display:

- 1.Cylinder spent error 4 with Yellow and Green lights on
- 2.Cyl. Lifespan error 9 with Yellow on and Green off

#### NHP light indication:

- 1.Yellow flashing and Green on (unit still working, might be initial start-up fill)
- 2.Yellow flashing and Green off (unit shut down)

#### NHB light indication:

- 1.NHB Yellow on

### CYLINDER REPLACEMENT PROCEDURE:

- 1.Turn off water supply to unit.
  - 2.Activate drain switch to completely empty water content (less than 10 min.)
  - 3.When drained, put switch back to the off position.
  - 4.Also open the main electrical disconnect switch and open plumbing door using the key.
  - 5.Remove the cylinder plugs by pulling vertically. The plugs are press-fitted over the electrode pins protruding from the top of the cylinder.
  - 6.Using a slot screwdriver, loosen the steam hose clamp(s) and pull steam hose off the cylinder vertically.
  - 7.Using a small slotted screwdriver, depress tab on the re-usable tie wrap, if present, around the middle of the cylinder. This will loosen the tie wrap to come apart for re-use later on.
  - 8.The cylinder is now ready to be lifted out of the unit.
- CAUTION: Cylinder and any un-drained water might still be HOT.
- 9.Always clean the drain valve before installing a new cylinder. (see further below)
  - 10.Remove the used cylinder and replace by a new one. Do not re-use cylinder.

### MANDATORY CLEANING OF THE DRAIN VALVE

- 1.Note that ring terminal for drain valve green ground wire is sandwiched between drain valve body and drain pan.
  - 2.Remove two screws securing drain valve body to drain pan. Disconnect the two slip-on terminals from the two tabs on the (24VAC) drain valve coil.
  - 3.Remove hose clip and hose connection from drain valve body.
  - 4.Drain valve assembly is now free to be taken to a sink for disassembly and cleaning.
- Important: Tapered end of spring must be installed toward the solenoid.
- 5.Clean out the end of the hose, and then reconnect it to the drain valve body with the clamp.
  - 6.Fit mounting screws through drain valve body, one through ring terminal on green ground wire.

WARNING: To prevent the possibility of electrical shock the green ground wire must be reinstalled before power is restored. Push the two slip-on terminals back onto the two tabs on the coil. The terminals, although not identical, are reversible.ox. 10 seconds).

## Periodic Maintenance Checklist & Quick Reference (p. 2 of 2)

Unit Serial #: \_\_\_\_\_ # of humidifiers: \_\_\_\_\_ Tag: \_\_\_\_\_

Unit type: \_\_\_\_\_ Voltage: \_\_\_\_\_ V/ \_\_\_\_\_ ph Steam output: \_\_\_\_\_ lbs./hr

Customer/Job: \_\_\_\_\_ Address: \_\_\_\_\_

Maintenance by: \_\_\_\_\_ Date of maintenance: \_\_\_\_/\_\_\_\_/\_\_\_\_

### HOW TO INSTALL THE REPLACEMENT CYLINDER

- 1.Reverse procedure should be followed to install new cylinder. Main disconnect is to be left open until cylinder is completely installed and reconnected.
- 2.Ensure that the re-usable tie wrap and mounting brackets within the unit secure the cylinder properly.
- 3.The cylinder plug wires are colour-coded in accordance with coloured dots beside the electrode pins on top of the cylinder.
- 4.This colour coding must be adhered to when replacing cylinder plugs on pins.
- 5.With cylinders having six primary voltage cylinder plugs, it should be noted that there are two of each colour.
- 6.Care must be taken so that cylinder leads of the same color are always directly opposite each other as indicated by the dot formation on the top of the cylinder.
- 7.The white cylinder plug on all units is for the high water sensor electrode, which always goes on the single pin surrounded by a plastic shoulder.
- 8.Ensure that cylinder plugs fit snugly on the pins.
- 9.If cylinder plugs become loose, it is best to obtain a new replacement plug. Consult factory.

### EXTENDED SHUTDOWN:

- 1.Before disconnecting power to the humidifier for a period of extended shutdown, ALWAYS DRAIN the cylinder first.
  - 2.Do NOT leave the switch in the DRAIN position indefinitely as the drain coil could burn out. Leave the switch in the OFF position and "open" the main external fused disconnect to stop power to the humidifier.
  - 3.Close the shut off valve in the water supply line feeding the humidifier. Lock the cabinet door(s) to prevent unauthorized tampering. All doors are factory supplied with keyed locks.  
**DO NOT LEAVE KEY IN LOCK. ACCESS SHOULD BE LIMITED TO AUTHORIZED PERSONNEL ONLY.**
  - 4.NHMC 3 day drain: As long as the NHMC is powered, it will automatically drain the cylinder when there has not been a call for humidity for an extended period of time.
  - 5.The cylinder will remain empty until there is a call for humidity at which time the fill valve will open and refill the cylinder.
- This feature will reduce the possibility of corrosion of the electrodes and the possible accumulation of algae and bacteria growing in the cylinder.

Remarks:



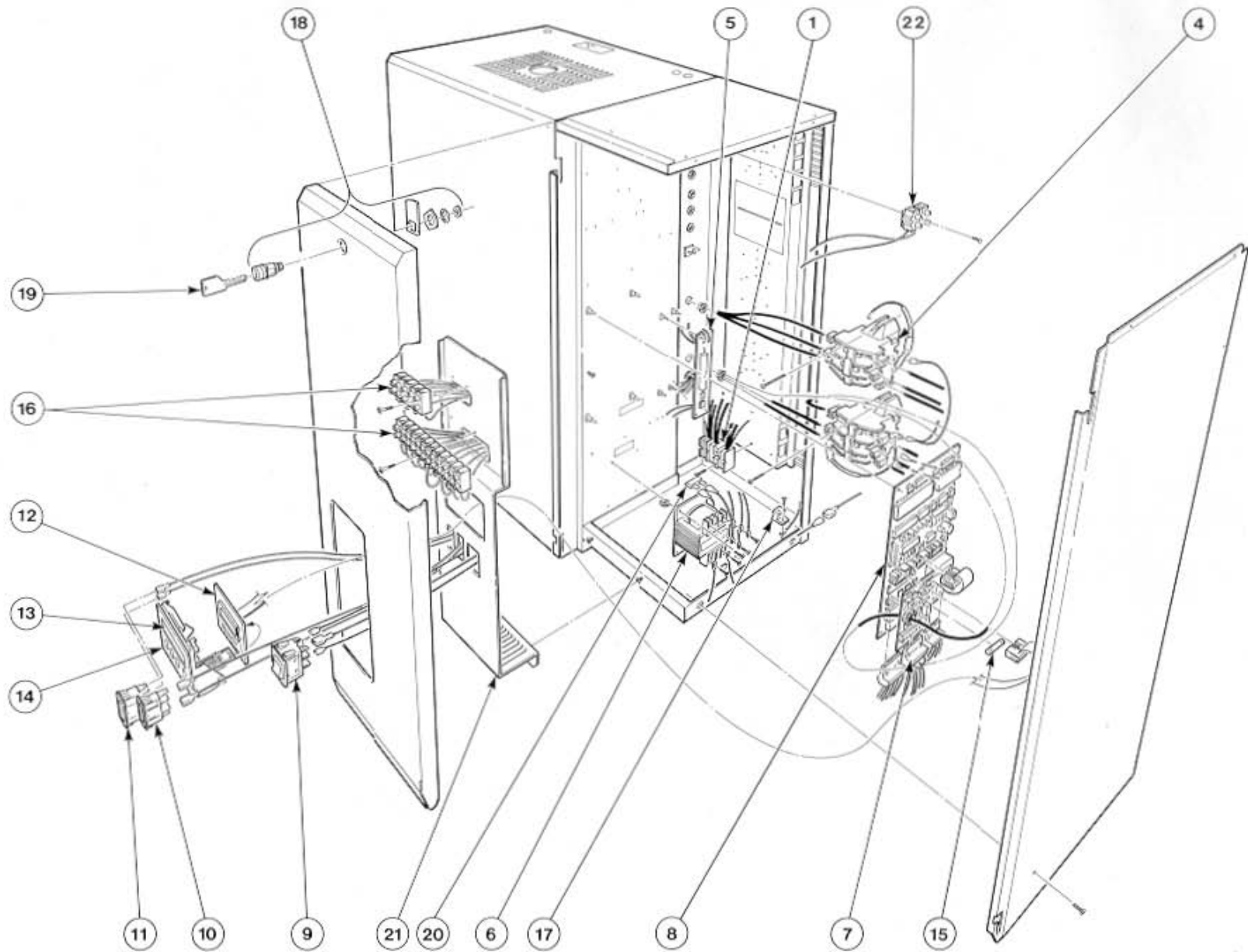



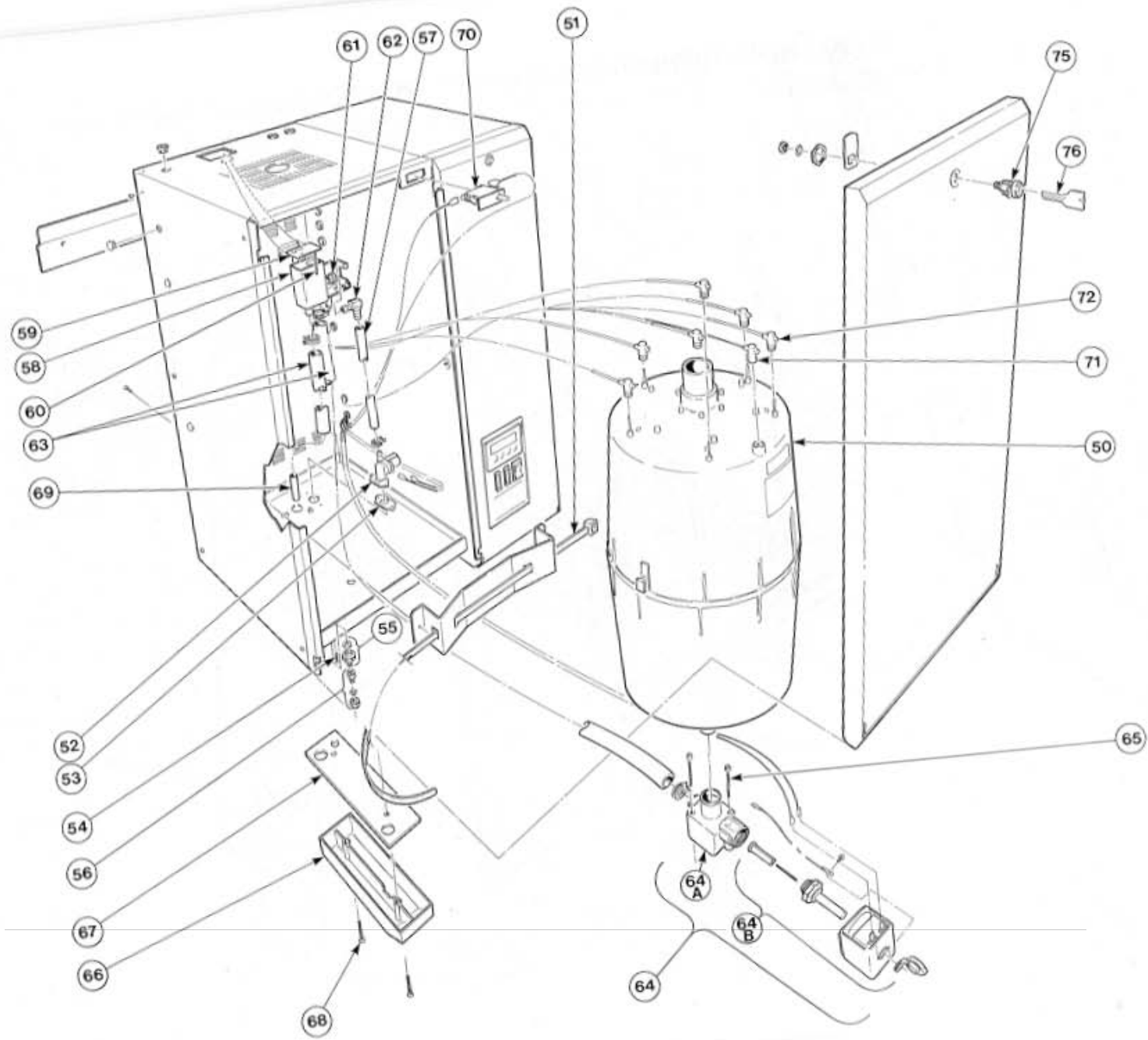





# LIMITED WARRANTY

---

NORTEC INDUSTRIES INCORPORATED and/or NORTEC AIR CONDITIONING INDUSTRIES LIMITED (hereinafter collectively referred to as THE COMPANY), warrant for a period of two years from date of shipment, that THE COMPANY's manufactured and assembled products, not otherwise expressly warranted (with the exception of the cylinder) are free from defects in material and workmanship. No warranty is made against corrosion, deterioration, or suitability of substituted materials used as a result of compliance with government regulations.

THE COMPANY's obligations and liabilities under this warranty are limited to furnishing replacement parts to the customer, F.O.B. THE COMPANY's factory, providing the defective part(s) is returned freight prepaid by the customer. Parts used for repairs are warranted for the balance of the term of the warranty on the original humidifier or 90 days, whichever is longer.

The warranties set forth herein are in lieu of all other warranties expressed or implied by law. No liability whatsoever shall be attached to THE COMPANY until said products have been paid for in full and then said liability shall be limited to the original purchase price for the product. Any further warranty must be in writing, signed by an officer of THE COMPANY.

THE COMPANY's limited warranty on accessories, not of NORTEC's manufacture, such as controls, humidistats, pumps, etc. is limited to the warranty of the original equipment manufacturer from date of original shipment of humidifier.

THE COMPANY makes no warranty and assumes no liability unless the equipment is installed in strict accordance with a copy of the catalog and installation manual in effect at the date of purchase and by a contractor approved by THE COMPANY to install such equipment.

THE COMPANY makes no warranty and assumes no liability whatsoever for consequential damage or damage resulting directly from misapplication, incorrect sizing or lack of proper maintenance of the equipment.

THE COMPANY retains the right to change the design, specification and performance criteria of its products without notice or obligation.

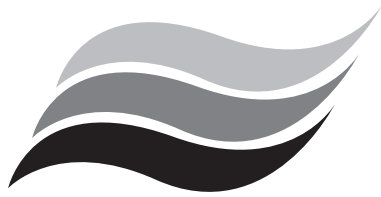

# **Nortec**<sup>®</sup>

[www.humidity.com](http://www.humidity.com)

Model # : \_\_\_\_\_

Serial # : \_\_\_\_\_

Cylinder # : \_\_\_\_\_

Cylinder Last Replaced:

\_\_\_\_\_  
MTH/DAY/YR

\_\_\_\_\_  
MTH/DAY/YR

\_\_\_\_\_  
MTH/DAY/YR



NORTEC INDUSTRIES INC.  
P.O. Box 698  
826 Proctor Avenue  
Ogdensburg, NY 13669

NORTEC AIR CONDITIONING  
INDUSTRIES LTD\*.  
2740 Fenton Road  
Ottawa, ON K1T 3T7

A WMH COMPANY

PRINTED IN CANADA